

智能超高速包缝机

High Speed Computerized Overlock Sewing Machine

使用说明书. 零件样本 Operating Manual & Parts List

注意： 为了安全地使用，请您在使用产品之前一定阅读本使用说明书。
另外，请您注意保管本使用说明书，以便随时查阅

NOTE: Read safety Instructions carefully and understand them before operation.
Retain this Instruction Manual for future reference.

P/N. 7810-100000 Rev01-2019

非常感谢您购买本公司的工业缝纫机。在使用缝纫机之前，请仔细阅读<为了您的安全使用>和使用说明书。

工业缝纫机的特性之一，是要在机针和旋梭等运动零部件附近进行操作，而这些零部件很容易引起受伤的危险，所以请在接受过培训的人员或有熟练操作技术的人员的指导下，正确地使用本缝纫机。

此样本是二零一九年八月的数据而制成的，后期零件更改，恕不另行通知。

为了您的安全使用

1. 安全使用的标记及其意义

本使用说明书及产品所使用的标记和图案记号是为了您的安全而正确地使用本产品，防止您及他人受到危害和损害。

表示方法及含义如下：

说明



危险

如果忽视此标记而进行了错误的操作，必将导致人员死亡或重伤。



注意

如果忽视此标记而进行了错误的操作，有可能会引起人员受伤及造成设备损坏。

图案和符号



符号△表示“应注意事项”。
三角中的图案表示必须要注意的内容。
(如左图的符号表示“注意受伤”。)



符号○表示“禁止”。



符号●表示“必须”。
圆圈中的图案表示必须要做的内容。
(如左图的符号表示“必须接地”。)

Thank you very much for buying our sewing machine. Before using your new machine, please read the safety instructions below and the explanations given in the Operation Instruction.

With industrial sewing machines, it is normal to carry out work while positioned directly in front of moving parts such as the needle and thread take-up lever, and consequently there is always a danger of injury that can be caused by these parts. Follow the instructions from training personnel and instructors regarding safe and correct operation before operating the machine so that you will know how to use it correctly.



This sample book is made in August 2019 and is subject to change without notice.

SAFETY INSTRUCTIONS

1. Safety indications and their meanings

This instruction manual and the indications and symbols that are used on the machine itself are provided in order to ensure safe operation of this machine and to prevent accidents and injury to yourself or other people. The meaning of these indications and symbols are given below.

Indications

 DANGER	The instructions which follow this term indicate situations where failure to follow the instructions will almost certainly result in death or severe injury.
 CAUTION	The instructions which follow this term indicate situations where failure to follow the instructions could cause injury when using the machine or physical damage to equipment and surroundings.

Symbols



..... This symbol (\triangle) indicates something that you should be careful of. The picture inside the triangle indicates the nature of the caution that must be taken. (For example, the symbol at left means "beware of injury".)



..... This symbol (\otimes) indicates something that you must not do.



..... This symbol (\bullet) indicates something that you must do. The picture inside the circle indicates the nature of the thing that must be done. (For example, the symbol at left means "you must make the ground connection".)

安全注意事项

危险



打开控制箱盖时，必须先关闭电源开关并将电源插头从插座上拔下，至少等待5分钟后，再打开控制箱盖。触摸带有高电压的区域将会造成人员伤亡。

注意

使用环境



应避免在强电气干扰源(如高频焊机)的附近使用缝纫机。
强电气干扰源可能会影响缝纫机的正确操作。



缝纫机的最佳工作环境是相对湿度在45%-85%的范围内，干燥或潮湿的环境均会影响缝纫机的正确操作。



电源电压的波动应该在额定电压的±10%以内的环境下使用。
电压大幅度的波动会影响缝纫机的正确操作。



使用时应避免暴露于直射的阳光下。
直射的阳光会影响缝纫机的正确操作。



电源容量应大于缝纫机的消耗能量。电源容量不足会影响缝纫机的正确操作。



万一发生雷电暴风雨时，关闭电源开关，并将电源插头从插座上拔下。雷电可能会影响缝纫机的正确操作。



环境温度应在5°C-35°C的范围内使用。
低温或高温会影响缝纫机的正确操作。

安装



请让受过培训的技术人员来安装缝纫机。



固定电缆时，不要过度弯曲电缆或用卡钉固定得过紧，会引起火灾或触电的危险。



请委托购买商店或电气专业人员进行电气配线。



如果使用带小脚轮的工作台，则应该固定小脚轮，使其不能移动。



安装工作必须由两人以上来完成。



缝纫机头倒下或竖起时，请用双手进行操作。单手操作时因缝纫机的重量万一滑落易导致受伤。



在安装完成前，请不要连接电源，如果误按启动开关，缝纫机动作会导致受伤。



使用润滑油或黄油时，务必戴好保护眼镜和保护手套等，以防润滑油落入眼中或沾在皮肤上，这是引起发炎的原因。
另外，润滑油或黄油不能饮用，否则会引起呕吐和腹泻。
将油放在小孩拿不到的地方。



请在切断电源后，再拔掉电源插头。不然易成为控制箱发生故障的原因。



必须接地。接地线不牢固，是造成触电或误动作的原因。

Notes On Safety







DANGER













Wait at least 5 minutes after turning off the power switch and disconnecting the power cord from the wall outlet before opening the face plate of the control box. Touching areas where high voltages are present can result in severe injury.

CAUTION

Environmental requirements

-  Use the sewing machine in an area which is free from sources of strong electrical noise such as high-frequency welders. Sources of strong electrical noise may cause problems with correct operation.
-  Any fluctuations in the power supply voltages should be within $\pm 10\%$ of the rated voltage for the machine. Voltage fluctuations which are greater than this may cause problems with correct operation.
-  The power supply capacity should be greater than the requirements for the sewing machine's electrical consumption. Insufficient power supply capacity may cause problems with correct operation.
-  The ambient temperature should be within the range of 5°C to 35°C during use. Temperatures which are lower or higher than this may cause problems with correct operation.
-  The relative humidity should be within the range of 45% to 85% during use, and no dew formation should occur in any devices. Excessively dry or humid environments and dew formation may cause problems with correct operation.
-  Avoid exposure to direct sunlight during use. Exposure to direct sunlight may cause problems with correct operation.
-  In the event of an electrical storm, turn off the power and disconnect the power cord from the wall outlet. Lightning may cause problems with correct operation.

Installation

-  Machine installation should only be carried out by a qualified technician.
-  Contact your dealer or a qualified electrician for any electrical work that may need to be done.
-  The installation should be carried out by two or more people.
-  Don't connect the power cord until installation is complete, otherwise the machine may operate if the foot switch is depressed by mistake, which could result in injury.
-  Be sure to connect the ground. If the ground connection is not secure, you run a high risk of receiving a serious electric shock, and problems with correct operation may also occur.
-  Install the safety covers to the machine head and motor.
-  Hold the machine head with both hands when tilting it back or returning it to its original position. Furthermore, after tilting back the machine head, do not push the face plate side or the pulley side from above, as this could cause the machine head to topple over, which may result in personal injury or damage to the machine.
-  All cords should be secured at least 25mm away from any moving parts. Furthermore, do not excessively bend the cords or secure them too firmly with staples, otherwise there is the danger that fire or electric shocks could occur.
-  If using a work table which has casters, the casters should be secured in such a way so that they cannot move.
-  Be sure to wear protective goggles and gloves when handling the lubricating oil and grease, so that they don't get into your eyes or onto your skin, otherwise inflammation can result. Furthermore, do not drink the oil or eat the grease under any circumstances, as they can cause vomiting and diarrhoea. Keep the oil out of the reach children.

安全注意事项

注意

缝纫

 本缝纫机仅限于接受过安全操作培训的人员使用。



为了安全起见，在使用本缝纫机之前，请安装保护装置。如果未安装这些安全装置就使用缝纫机，会造成人身伤害及缝纫机损坏。

 本缝纫机不能用于除缝纫以外的任何其他用途。



缝纫过程中不要触摸任何活动部件或将物件靠在运动部件上，因为这会导致受伤或缝纫机损坏。

 发生下列情况时，请切断电源。否则误按动启动开关，缝纫机动作会导致受伤。

- 机针穿线时
- 更换机针或梭芯时
- 缝纫机不使用，或人离开缝纫机时



如果缝纫机操作中发生误动作，或者听到异常的噪声或闻到异常的气味，应立即切断电源。然后与购买商店或受过培训的技术人员联系。

 如果使用带小脚轮的工作台，则应该固定小脚轮，使其不能移动。



如果缝纫机出现故障时，请与购买商店或受过培训的技术人员联系。

清洁

 在开始清洁作业前，请切断电源。如果误踩了脚开关，缝纫机动作会导致人员受伤。



使用润滑油或黄油时，务必戴好保护眼镜和保护手套等，以防润滑油落入眼中或沾在皮肤上，这是引起发炎的原因，另外，润滑油或黄油不能饮用，否则会引起呕吐和腹泻。将油放在小孩拿不到的地方。

Notes On Safety

CAUTION

Sewing



This sewing machine should only be used by operators who have received the necessary training in safe use beforehand.



If using a work table which has casters, the casters should be secured in such a way so that they cannot move.



The sewing machine should not be used for any applications other than sewing.



Attach all safety devices before using the sewing machine. If the machine is used without these devices attached, injury may result.



Be sure to wear protective goggles when using the machine.
If goggles are not worn, there is the danger that if a needle breaks, parts of the broken needle may enter your eyes and injury may result.



Do not touch any of the moving parts or press any objects against the machine while sewing as this may result in personal injury or damage to the machine.



Turn off the power switch at the following times, otherwise the machine may operate if the foot switch is depressed by mistake, which could result in injury.

- When threading the needle
- When replacing the needle and bobbin
- When not using the machine and when leaving the machine unattended



If an error occurs in machine operation, or if abnormal noises or smells are noticed, immediately turn off the power switch. Then contact your nearest dealer or a qualified technician.



If the machine develops a problem, contact your nearest dealer or a qualified technician.

Cleaning



Turn off the power switch before carrying out cleaning, otherwise the machine may operate if the foot switch is depressed by mistake, which could result in injury.



Be sure to wear protective goggles and gloves when handling the lubricating oil and grease, so that they do not get into your eyes or onto your skin, otherwise inflammation can result. Furthermore, do not drink the oil or eat the grease under any circumstances, as they can cause vomiting and diarrhoea. Keep the oil out of the reach of children.

目录 CONTENTS

1. 台板加工图 Schematic Diagram Of The Machine Table	1
2. 规格 Specifications	2
3. 供油 Lubrication	2
4. 手动给油 Manual Lubrication	2
5. 给HR装置供油 Filling The Hr Witch Silicon Oil	3
6. 穿线的方法 Threading	3
7. 压脚压力的调节 Adjusting The Presser Foot Pressure	3
8. 差动比的调节 Adjusting The Diff. Feed Ratio	4
9. 针脚长度的调节 Adjusting The Stitch Length	4
10. 线状态的调节 Adjusting The Thread Tension	4
11. 缝纫机的清扫 Cleaning The Machine	5
12. 换针 Replacing The Needle	5
13. 检查机油的循环 Checking The Oil Circulation	5
14. 油过滤器的清洁与更换 Checking And Replace The Oil Filter	6
15. 下刀片的更换 Replacing The Lower Knife	6

2. 规格 Specifications

机型 Model	三线 Three thread	四线 Four thread	五线 Five thread	五线厚料 Five thread for heavy material
线迹长度 Stitch length	3.8			
最高缝纫转速 Maximum speed	7500	7000	7000	5500
机针 Needle	DCX27 #11	DCX27 #11	DCX27 #14	DPX27 #18

针号对照表 Comparison Table Of Equivalent Sizes

日本针号 Japanese size	#	9	11	14	16	18	21
德国针号 Metric size	Nm	65	75	90	100	110	130

3. 供油 Lubrication

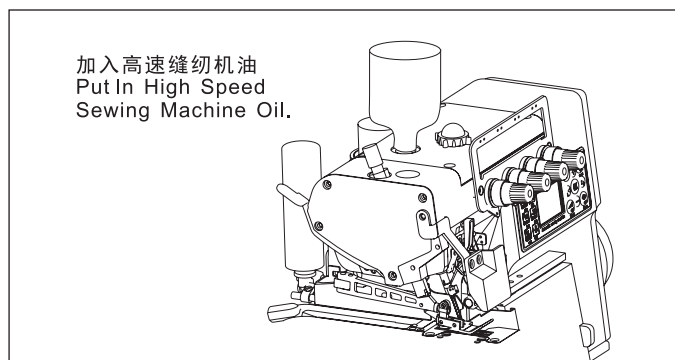

加油量是使油处于线H与L线之间为好。当油低于L线时，就要及时补充机油。

EN

After filling the pan, the top of the indicator should lie between (H) and (L) lines. Add oil, when the oil level indicator reaches or goes below (L).

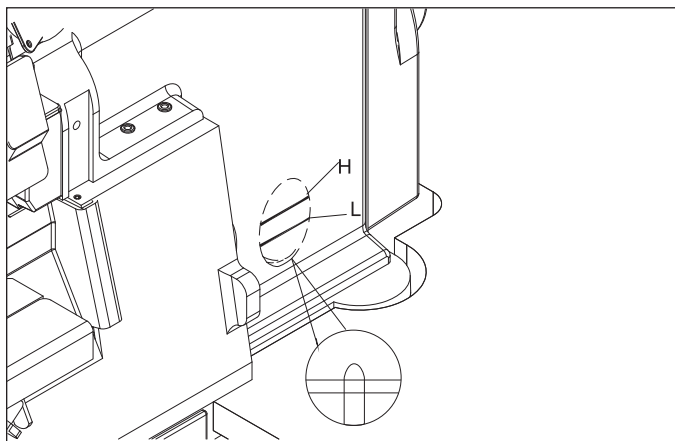

4. 手动给油 Manual Lubrication

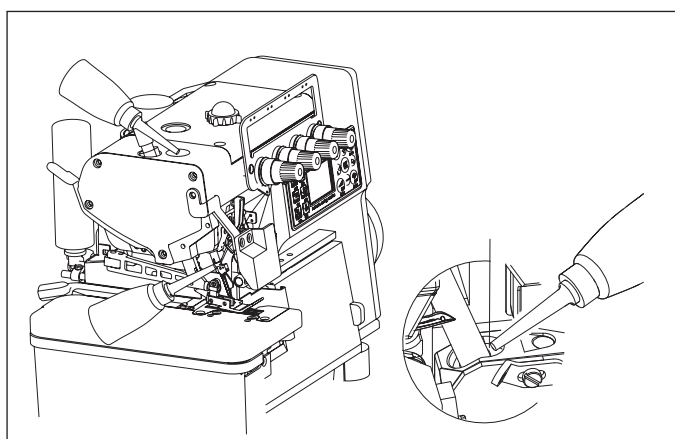

手动给油是在缝纫机最初开始使用时，或相当一段时间没有用了时，请供给2-3滴油。

EN

Apply 2 or 3 drops of oil by hand when the machine is used for the first time or has been left unused for some time.

5. 给HR装置供油 Filling The HR Witch Silicon Oil

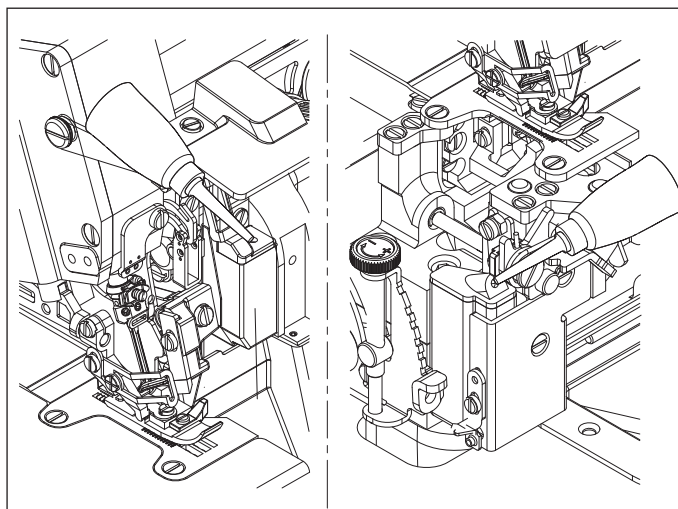

为防止断线，尽早给HR装置供油。

注:关于购买硅油，请咨询缝纫机代销店或本公司营业部。

EN

Fill the HR device with oil be for it is too low in order to prevent needle thread breakage and fabric damage.

Note: Use Pegasus recommended silicon oil. (UNION CARBIDE CORPORATION) UCC L-45(10)

6. 穿线的方法 Threading

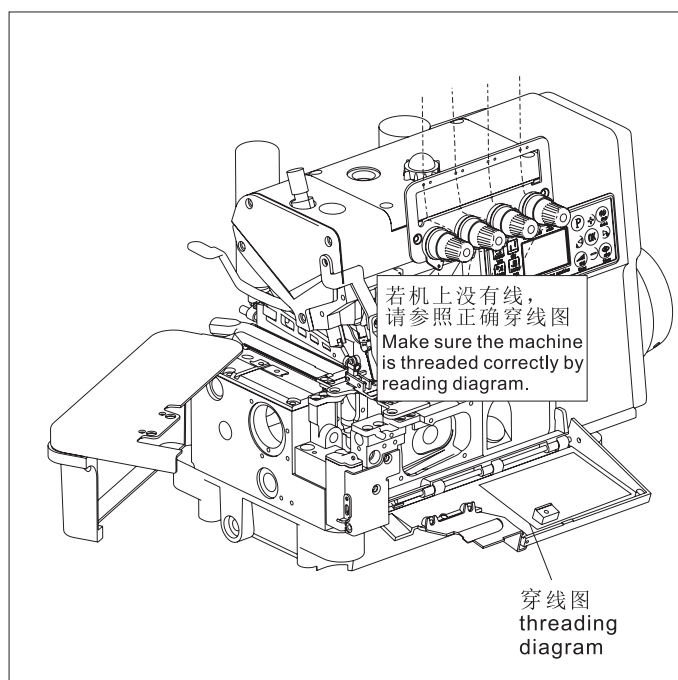

1)打开压脚及机盖（三处）

2)把机上原有的线与缝纫机用线绑结在一起。

3)针线

将线拉到针眼前，剪掉接头再次穿好针线。

4)弯针线

线拉出接头后，剪掉接线头。

EN

1)Open three covers. Sewing the presser foot aside.

2)Knot the preset thread and the thread being used together to thread the machine.

3)Needle thread

Trim the knots off neatly before passing through the eye of the needle to rethread .

4)looper thread

Trim the knots off neatly after passing through the the eye of the looper.

7. 压脚压力的调节 Adjusting The Presser Foot Pressure

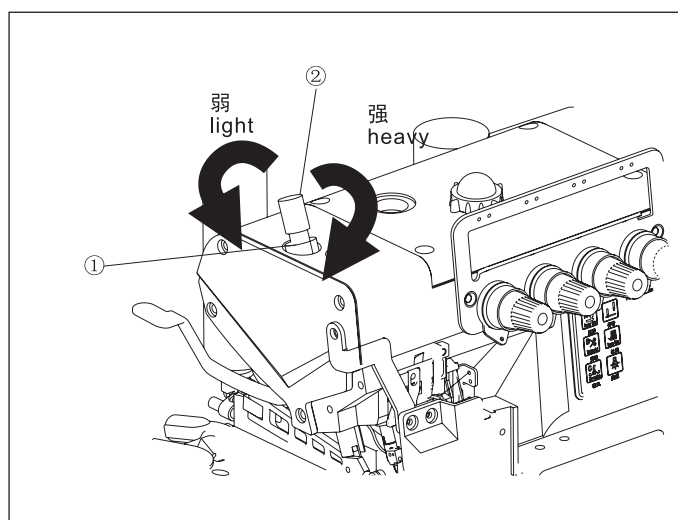

1)压脚压力的调节是松开螺帽①和旋转螺丝②来进行的。在能取得平稳针脚的范围內，尽量调的松一些为好。

EN

1)Loosen adjusting nu① and turn adjusting screw ② to adjust the presser foot pressure.

It should be as light as possible, yet be sufficient to obtain the proper stitch formation.

8. 差动比的调节 Adjusting The Diff. Feed Ratio

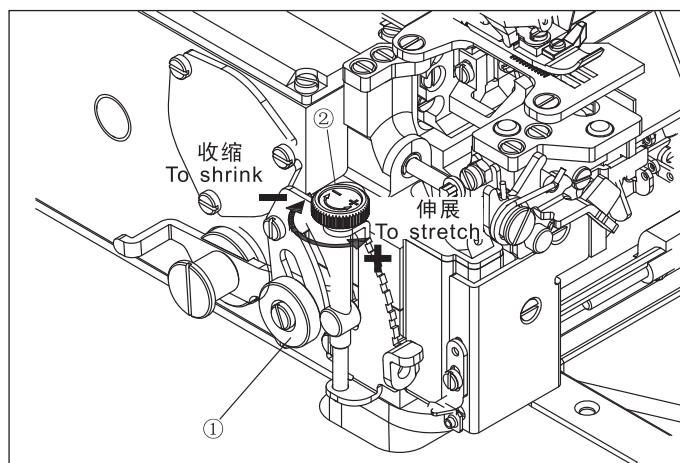

1) 差动比是通过松开螺帽①后,把调节杆②上下移动来进行调节的.调节后请拧紧螺帽①.

EN

1) Loosen the nut ① and move the lever up ② and down to obtain the correct differential feed ratio, then tighten nut ①.

9. 针脚长度的调节 Adjusting The Stitch Length

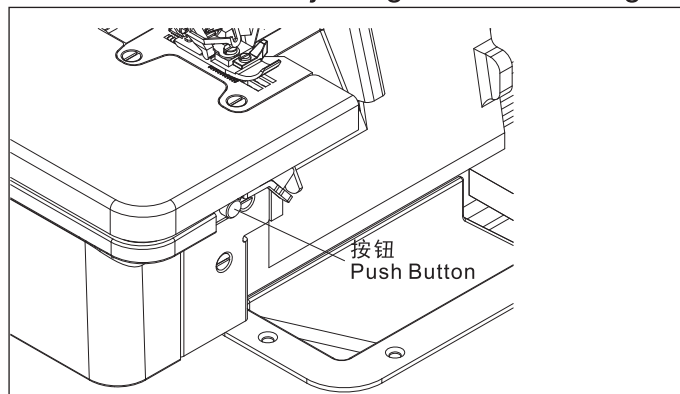

1) 摁住按钮,转动皮带轮,按钮会陷进更深处。
2) 这时边摁住按钮,边转动皮带轮,使校准标记对准希望的数值。
注: 针脚长度的调节务必请在调节差动比之后进行调节。

EN

1) while pressing the button, turn the handwheel to seek the position at the push button goes further into the depth.
2) then, keeping the push button pressed, turn the handwheel and set the desired scale to the aligning mark.

Note: Stitch length adjustment must only be made after the differential feed ratio has been changed.

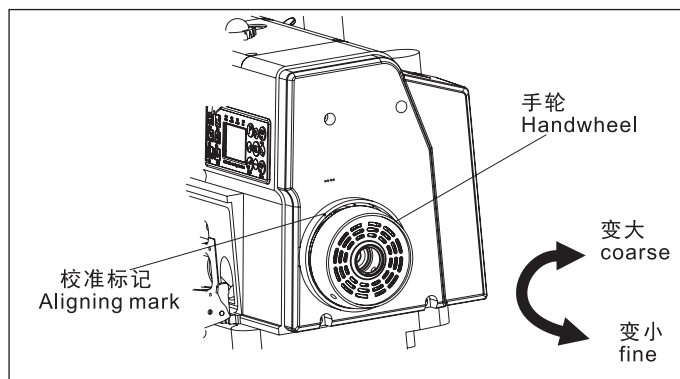

10. 线状态的调节 Adjusting The Thread Tension

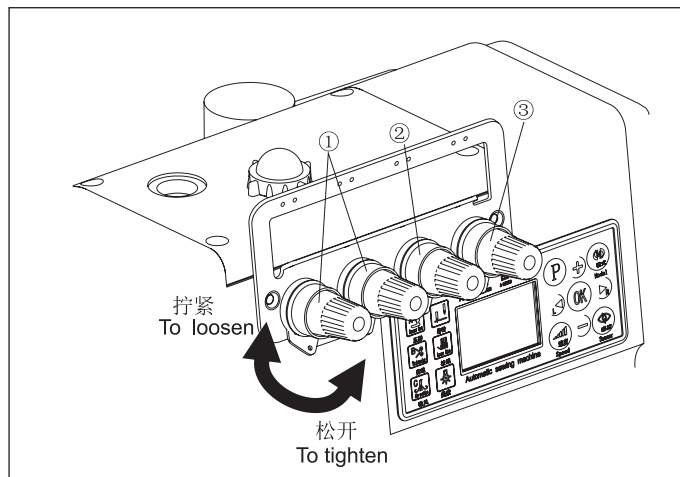

1) 线状态的调节是用针线夹线螺母①,上装饰上弯针夹线螺母②,下弯针夹线螺母③来进行调节。

EN

1) Make tension adjustments with the needle thread knob ①, the top cover thread knob ②, and the lower looper knob ③.

11. 缝纫机的清扫 Cleaning The Machine

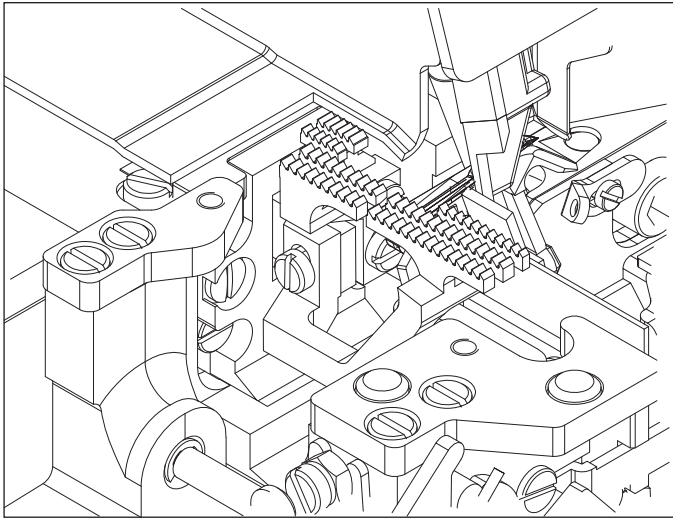

1) 缝纫机的清扫，以针板槽及送布牙周围为主。

EN

1) Mainly the slots of the needle plate and the feed rows should be cleaned.

12. 换针 Replacing The Needle

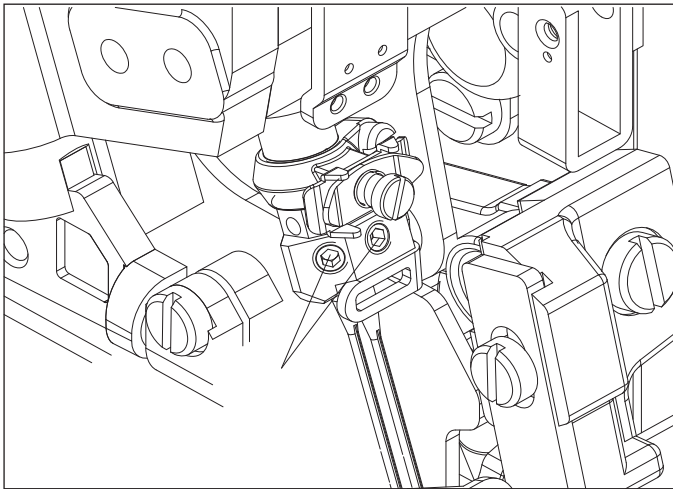

1) 准确辨认针的前后，请将针凹向着后方，即背向操作者进行安装。

2) 针要牢固的插到孔的最深处。

EN

1) Check the needle carefully to see that the scarf is turned to the rear of the machine.

2) Insert the needle to the proper depth, and fasten securely.

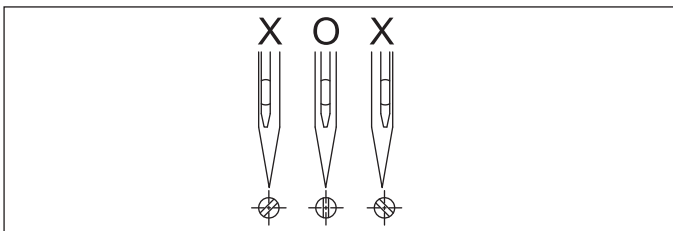

13. 检查机油的循环 Checking The Oil Circulation

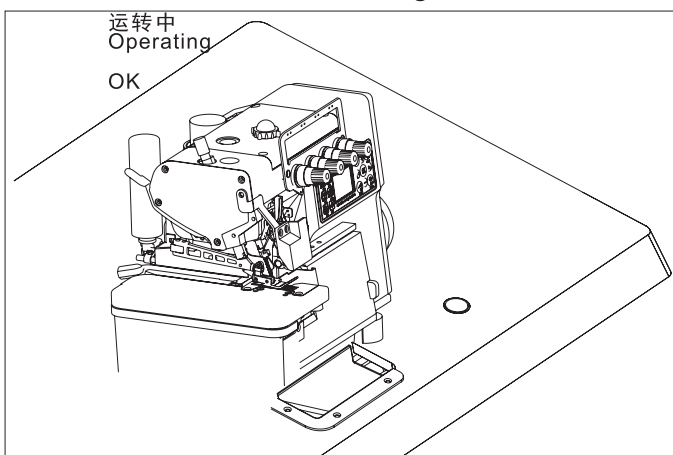

1) 检查机油的循环状况，请在加好油后，通过油窗检查机油的循环状况是否良好。

EN

1) Check the status of oil cycle, after adding the oil, please check the status of oil recycle through oil window.

14.油过滤器的清洁与更换 Checking And Replace The Oil Filter

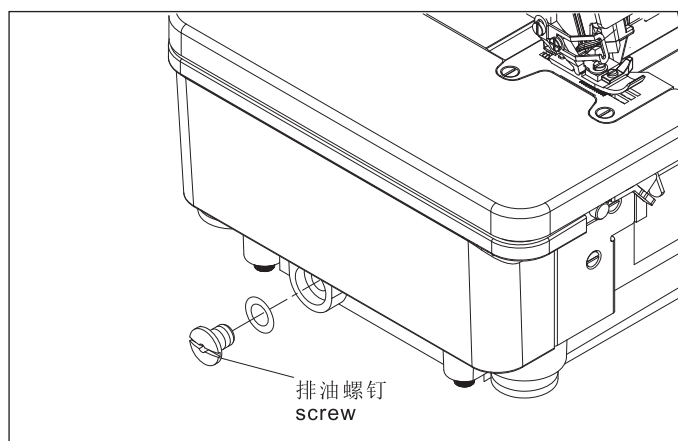

1) 机油的更换, 请在使用开始1个月后更换一次, 然后, 每6个月更换一次。

EN

1) Replacing the oil one moth after the first use and every six months there after.

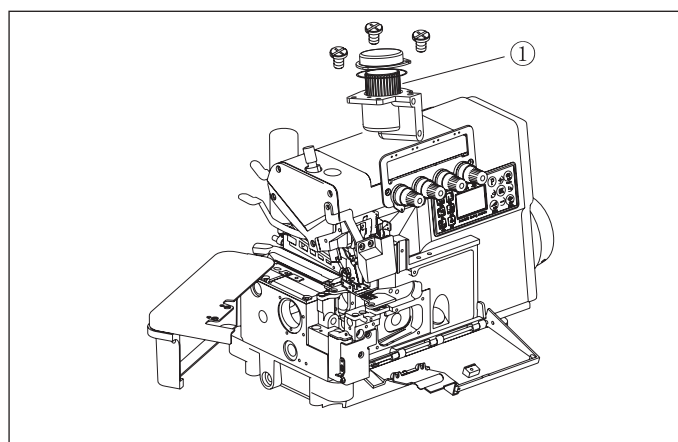

2) 机油过滤器①, 请每隔6个月清洁或更换一次。
注: 缝纫机附带有UT装置时, 请拆下螺线管托架。

EN

2) Check and replace the oil filter every six months.
Note: on machines fit with a UT device, remove the solenoid bracket.

15.下刀片的更换 Replacing The Lower Knife

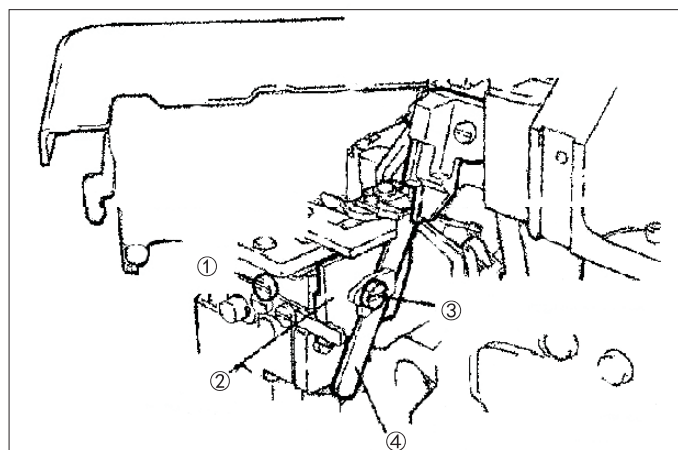

卸下下刀片

- 1) 拧开螺丝①。
- 2) 把下刀架推向左边, 用螺丝①暂时固定。
- 3) 松开螺钉②③。
- 4) 取下下刀片④。

EN

To remove the lower knife

- 1) Loosen the screw①.
- 2) Temporarily screw ① after sliding the lower knife holder ② to the left.
- 3) Loosen the screw③.
- 4) Remove the lower knife④.

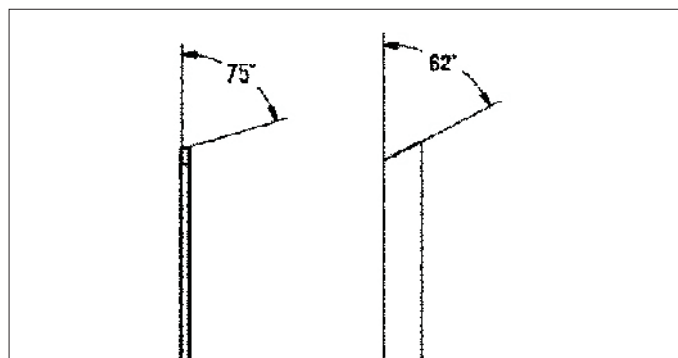

下刀片正确的研磨角度

EN

Correct angles to resharpen the lower knife.

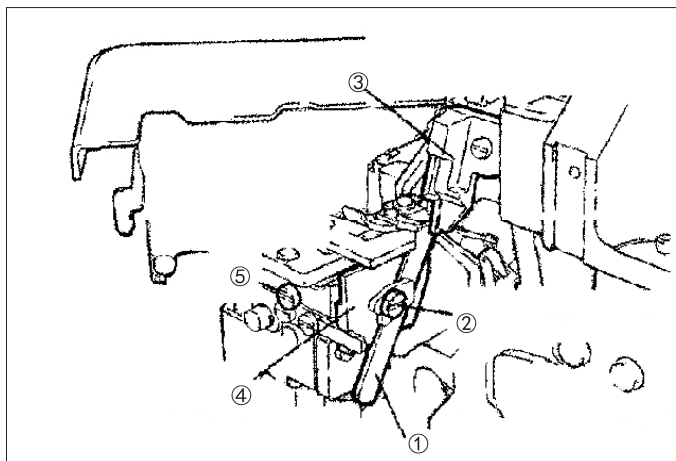

安装下刀片

- 1) 装入下刀片①。
- 2) 拧紧螺丝②。
- 3) 转动手轮将上刀③移动对准如左图所示位置。
- 4) 松开螺丝⑤，下刀架④侧向右移动。

EN

To replace the lower knife

- 1) Insert the lower knife①.
- 2) Tighten the screw②.
- 3) Turn the handwheel on the knife ③ mobile alignment as shown in the position.
- 4) Loosening the screw⑤ makes the lower knife ④holder slide to the right.

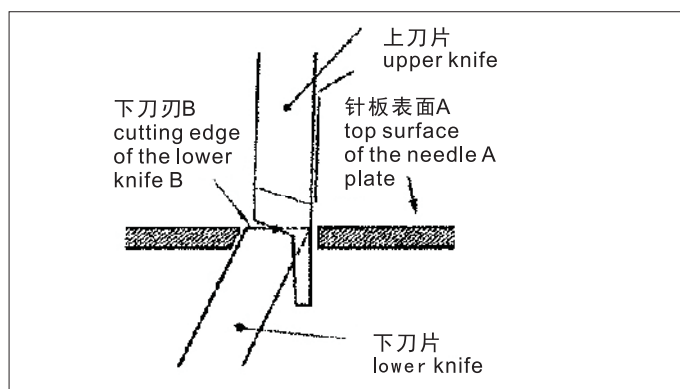

使针板表面A与下刀刃B处于相同水平位置。
装好下刀片后进行剪线，确认剪线状况。

EN

Make the surface of the needle plate is in the same horizontal position as the lower blade.

After the blade is installed, cut the thread and check the thread cutting condition.

调整基准表
Standard adjustment form

No.	机型 Model	针高度 (±0.1) Height of needle	下弯针 引量 Lower looper pendulum amplitude	上弯针 Upper looper				二重环 弯针引量 Double chainstitch looper pendulum amplitude	送牙 Feed dog				
				出量 Distance between upper looper and needle	高度 Height	弯针架 左右位置 Looper holder left and right position	上弯针座 安装方向 Upper looper seat installation direction		送齿倾斜度 Slope	送齿 高度 Height	上送布牙高度 (按上送齿 上面) Height of feed dog (The height over needle plate)	辅助送 齿段差 Auxiliary feed segment difference	送布偏 心量 Feed eccentricity
1	三线 Three thread	10.5	3.8	4.4-4.7	10.8	14.5	左 Left		针板上表面水平 Parallel to the needle plate surface	0.8	0.2	0.5	0.35-2
2	四线 Four thread	10.5	3.8	5.4-5.7	10.5	13.5	右 Right		针板上表面水平 Parallel to the needle plate surface	0.8	0.2	0.5	0.35-2
3	五线 Five thread	10.5	3.8	4.4-4.7	10.8	14.5	左 Left	1.5	针板上表面水平 Parallel to the needle plate surface	0.8	0.2	0.5	0.35-2

零件目录 PARTS CONTENTS

A .机壳部件Machine Bed Frame Mechanism	1
B .罩壳部件 Cover Mechanism	3
C .主轴驱动部件 Crank Shaft Drive Mechanism	7
D .过线夹线部件 Thread Tension Mechanism	9
E .过线挑线部件 Thread Guide & Thead Take-Up Mechanism	11
F .针杆部件 Needle Mechanism	13
G .上弯针部件 Upper Looper Driver Mechianiam	17
H .下弯针部件 Lower Looper Driver Mechianiam	19
I .前弯针部件 Chain Stitch Looper Mechanism	21
J .差动调节部件 Feed Mechanism	23
K .上下切刀部件Knife Drive Mechanism	27
L .抬压脚部件Press Foot Mechanism	29
M .润滑部件 Lubrication Mechanism	31
N .线架与附件 Accessories Mechanism	35
O .E4专用部件 Special Mechanism	37
P .全自动部件 Automatic Thread Trimming Mechanism	39
Q .直驱部件 Direct Drive Mechanism	41

A.机壳部件 Machine Bed Frame Mechanism

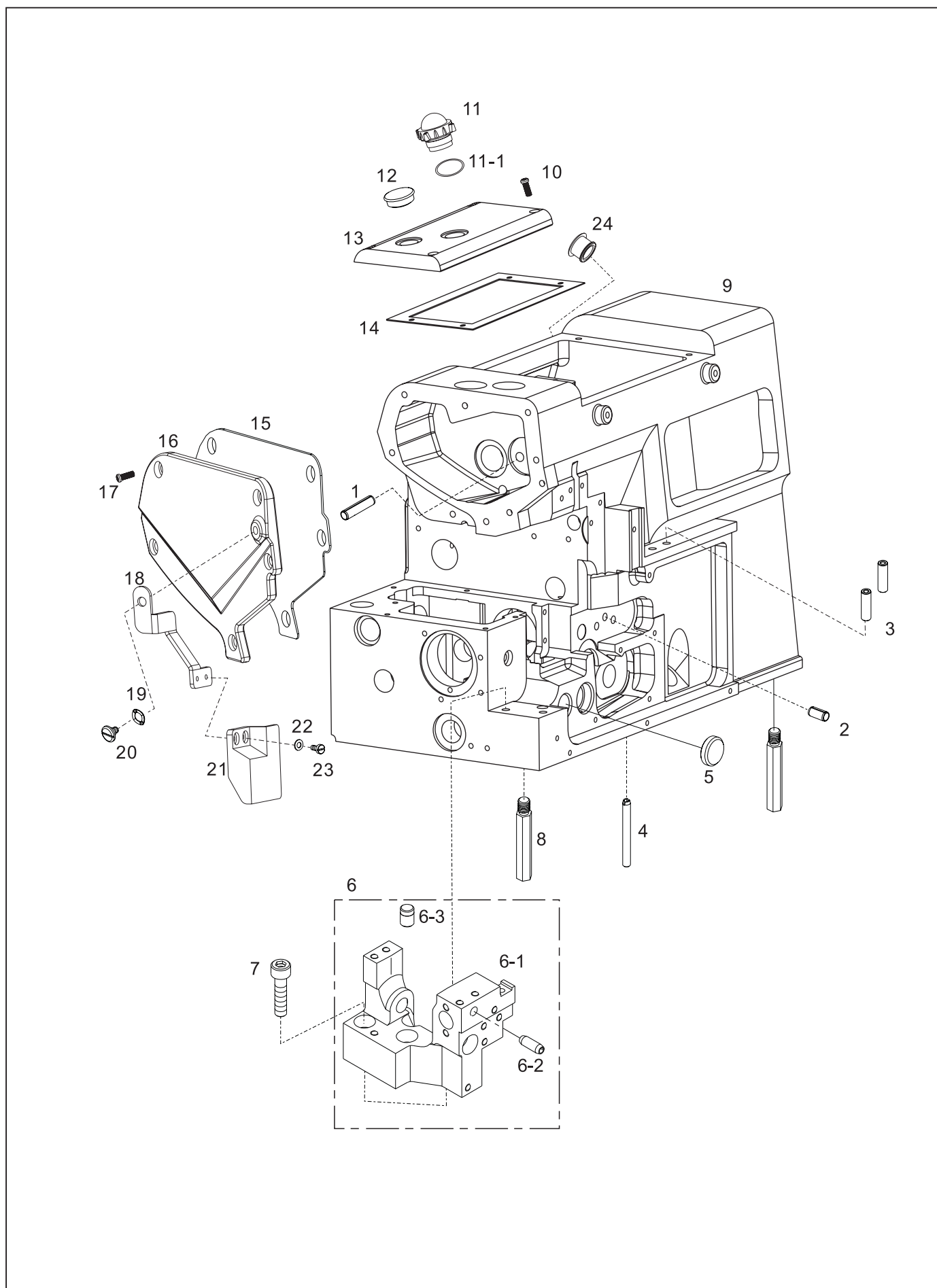

A.机壳部件 Machine Bed Frame Mechanism

序号 NO.	图号 REF NO.	名称	DESCRIPTION	数量 AMT			
				3线	4线	5线	5H
A-1	197-17-2005	针杆供油管限位开口销	Spring Pin $\phi 5 \times 14$	1	1	1	1
A-2	41-10501000-08	滑块定位销	Spring Pin $\phi 5 \times 10$	1	1	1	1
A-3	2316-01-02	弯针过线管	Pipe	2	2	2	2
A-4	2316-01-03	油导向销	Pin	1	1	1	1
A-5	209-10-03	前弯针轴孔橡皮塞	Plug	1	1	1	
A-6	2316-01-04	针板垫支架组件	Bracket Assy	1	1	1	1
A-6-1	2316-01-04-01	针板垫支架	Bracket	1	1	1	1
A-6-2	41-20501400-08	缝台限位开口销	Spring Pin	1	1	1	1
A-6-3	41-10700800-08	针板支架定位销	Pin	1	1	1	1
A-7	12-60602522-01	针板垫支架螺钉	Bolt	2	2	2	2
A-8	209-01-19	机头支柱	Bed Pin	4	4	4	4
A-9	2319-01-01	机壳	Frame	1	1	1	1
A-10	12-40401625-01	上盖螺钉	Screw M4X16	4	4	4	4
A-11	203-01-25	油窗	Oil Sight Window	1	1	1	1
A-11-1	209-02-05	O型圈	O Ring	1	1	1	1
A-12	2316-02-04	上盖橡皮塞	Plug	1	1	1	1
A-13	2319-01-02	上盖	Top Cover	1	1	1	1
A-14	2319-01-03	上盖密封垫	Gasket	1	1	1	1
A-15	2319-01-05	面板密封垫	Gasket	1	1	1	1
A-16	2319-01-04	面板	Left Cover	1	1	1	1
A-17	12-40401025-01	左盖板螺钉	Screw M4X10	5	5	5	5
A-18	2319-01-10	防护罩支架	Bracket	1	1	1	1
A-19	23-06503110-09	防护罩支架波型垫片	Washer $\phi 6.8 \times \phi 11.2 \times 1.3$	1	1	1	1
A-20	301-10-16	防护罩支架螺钉	Screw M11/64-40, $\phi 6 \times 6.5 \times 3.5$	1	1	1	1
A-21	2316-02-26	防护罩	Eye Guard	1	1	1	1
A-22	21-03405070-01	防护罩垫圈	Washer $\phi 3.4 \times \phi 7 \times 0.5$	2	2	2	2
A-23	12-60300520-01A	防护罩螺钉	Screw	2	2	2	2
A-24	423-07-01	橡皮塞	Plug5	1	1	1	1

B. 罩壳部件 Cover Mechanism

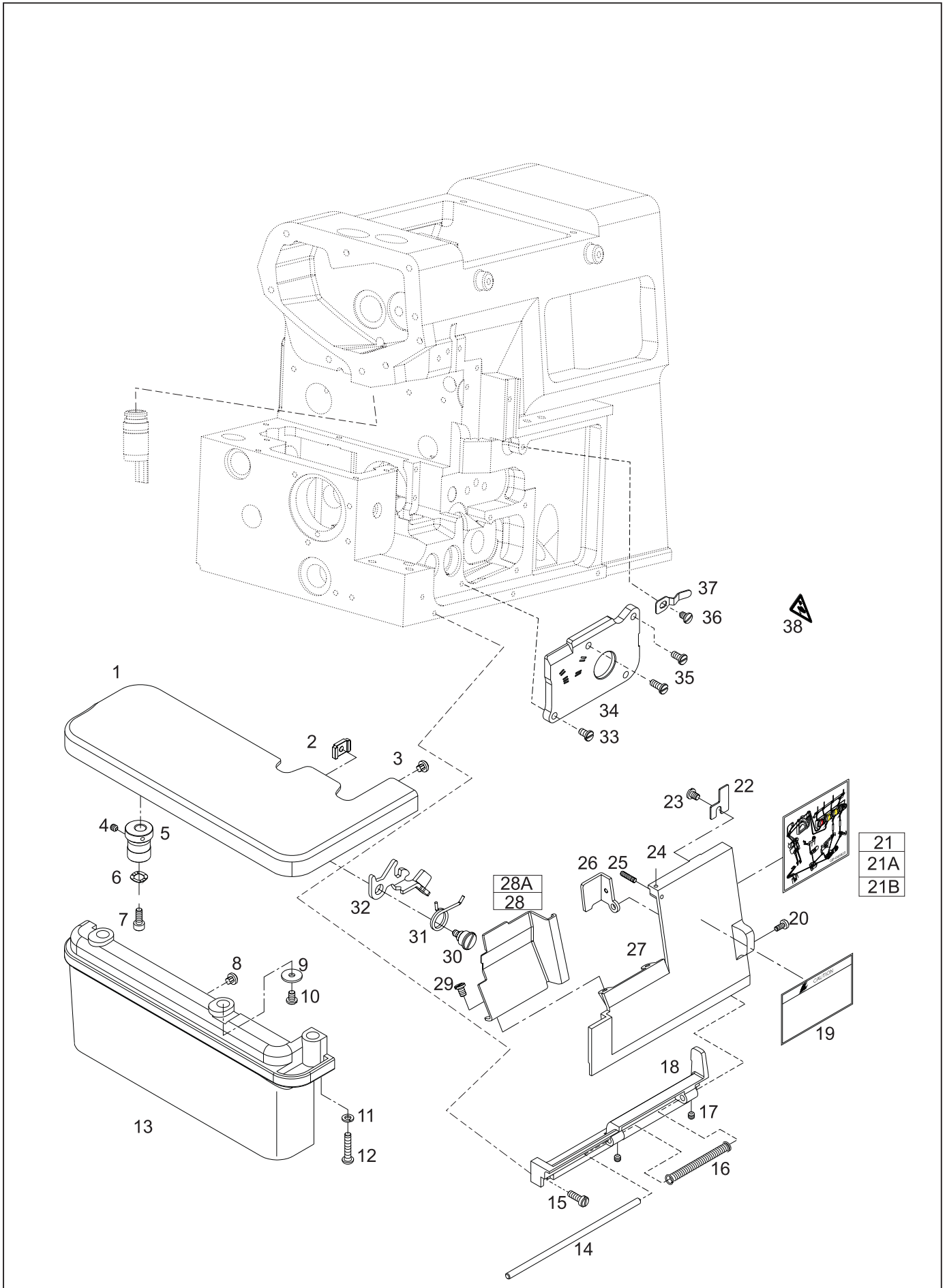

B.罩壳部件 Cover Mechanism

序号 NO.	图号 REF NO.	名称	DESCRIPTION	数量 AMT			
				3线	4线	5线	5H
B-1	2316-01-16	缝台组件	Cloth Plate Ass'y	1	1	1	1
B-2	2316-02-24	缝台开启扳手定向螺母	Bracket	1	1	1	1
B-3	209-03-14	缝台开启扳手架缓冲垫	Cushion Rubber	1	1	1	1
B-4	12-80400412-01	缝台转轴套紧固螺钉	Screw M4x4	1	1	1	1
B-5	2316-02-17	缝台转轴套	Sewing Table Shaft Sleeve	1	1	1	1
B-6	23-06203110-09	缝台转轴波型垫圈	Washer	1	1	1	1
B-7	2316-02-18	缝台转轴轴位螺钉	Screw	1	1	1	1
B-8	209-03-14	缝台下罩壳橡胶	Cushion Rubber	1	1	1	1
B-9	21-05111110-02	缝台下罩壳链接垫圈	Washer	2	2	2	2
B-10	12-40400825-01	缝台下罩壳链接螺钉	Screw ϕ m4x8	2	2	2	2
B-11	22-04000000-08	缝台下罩壳链接外弹簧垫圈	Washer ϕ 4	1	1	1	1
B-12	12-40402025-01	缝台下罩壳链接外螺钉	Screw M4x20	1	1	1	1
B-13	2316-02-19	缝台下罩壳	Side Cover	1	1	1	1
B-14	2319-01-11	前罩壳铰链轴	Pin ϕ 4x120	1	1	1	1
B-15	12-40401225-01	前罩壳铰链螺钉	Screw M4x12	3	3	3	3
B-16	209-02-32	前罩壳铰链轴簧	Spring ϕ 0.8	1	1	1	1
B-17	12-80400412-01	前罩壳铰链轴螺钉	Screw M4x4	1	1	1	1
B-18	2319-01-07	前罩壳铰链	Hinge	1	1	1	1
B-19	44-00000001-01	前罩壳安全警示标签	Caution Label	1	1	1	1
B-20	12-40300625-01	前罩壳打开左右限位板螺钉	Screw M3x6	1	1	1	1
B-21	2316-02-14	三线穿线指示图	Threading Diagram1	1			
B-21A	2316-02-14A	四线穿线指示图	Threading Diagram1		1		
B-21B	2316-02-14B	五线穿线指示图	Threading Diagram1			1	1
B-22	2316-02-11	前罩壳限位板	Latch T=0.9	1	1	1	1
B-23	12-40400525-01	前罩壳限位板螺钉	Screw M4x5	1	1	1	1
B-24	12-80300412-01	前罩壳左罩板限位销螺钉	Screw M3x4	1	1	1	1
B-25	12-80301212-01	前罩壳左罩板限位销	Screw M3x12	1	1	1	1
B-26	2316-02-10	前罩壳打开左右限位板	Latch T=2.0	1	1	1	1
B-27	2319-01-06	前罩壳	Front Cover(right)	1	1	1	1
B-28	2316-02-12	五线前罩壳左罩板	Front Cover(left)			1	1
B-28A	2316-02-12A	三四线前罩壳左罩板	Front Cover(left)	1	1		
B-29	12-40400525-01	前罩壳左罩板螺钉	Screw M4x5	2	2	2	2
B-30	2316-02-22	缝台开启扳手轴位螺钉	Screw M4	1	1	1	1
B-31	2316-02-33	缝台开启扳手复位扭簧	Spring	1	1	1	1
B-32	2316-02-21	缝台开启扳手	Plate Hand	1	1	1	1
B-33	12-40400825-01	上弯针前密封板螺钉	Screw M4x8	2	2	2	2
B-34	2316-02-13	上弯针前密封板	Cover T=5.5	1	1	1	1
B-35	12-40401225-01	上弯针下过线螺钉	Screw M4x12	2	2	2	2
B-36	12-40400825-01	前罩壳固定簧螺钉	Screw M4x8	1	1	1	1
B-37	209-02-15	前罩壳固定簧	Flat Spring T=0.7	1	1	1	1
B-38	44-00000006-00	三角警示标签	Label	1	1	1	1

B. 罩壳部件 Cover Mechanism

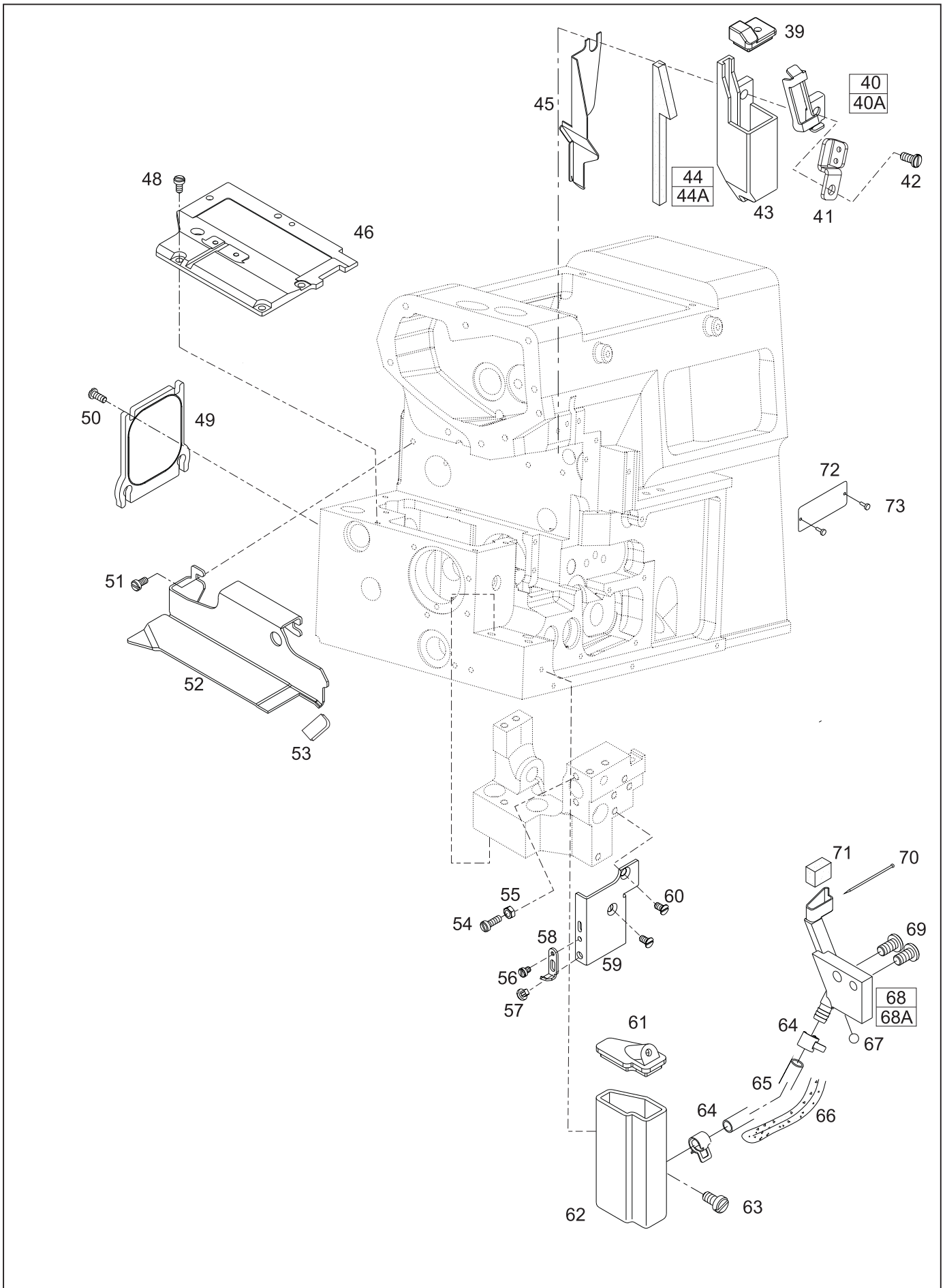

B.罩壳部件 Cover Mechanism

序号 NO.	图号 REF NO.	名称	DESCRIPTION	数量 AMT			
				3线	4线	5线	5H
B-39	2316-02-32	面线硅油盒盖	Cover	1	1	1	1
B-40	2316-02-34	面线硅油盒过线架	Thread Guide	1	1		
B-40A	2316-02-34A	面线硅油盒过线架	Thread Guide			1	1
B-41	2319-01-09	机针过线板	Tension Guide	1	1	1	1
B-42	12-40401225-01	面线硅油盒压板螺钉	Screw M4x12	1	1	1	1
B-43	2316-02-31	面线硅油盒	Silicone Oil Reservoir(upper)	1	1	1	1
B-44	2316-02-33	面线硅油毡	Felt T=4.0	1	1		
B-44A	2316-02-33A	面线硅油毡	Felt T=4.0			1	1
B-45	2316-02-35	面线硅油盒左挡板	Cover T=0.5	1	1	1	1
B-46	2319-01-30	机壳左上盖板	Cover	1	1	1	1
B-48	12-90400820-01	机壳左上盖板螺钉	Screw M4x8	5	5	5	5
B-49	2316-02-30	后盖板组件	Cover Plate	1	1	1	1
B-50	16-40401025-01	后盖板螺钉	Screw M4x12	4	4	4	4
B-51	12-40400825-01	缝台右挡板螺钉	Screw M4x8	2	2	2	2
B-52	2316-02-25	缝台右挡板	Fabric Guide T=1.6	1	1	1	1
B-53	2316-02-43	导布板海绵垫	Sponge Cushion	1	1	1	1
B-54	12-40401625-01	缝台限位调节螺钉	Screw M4x16	1	1	1	1
B-55	14-60403020-01	缝台限位调节螺母	Nut M4 T=3	1	1	1	1
B-56	12-40350425-01	缝台下罩壳限位片螺钉	Screw M3.5x4	1	1	1	1
B-57	209-03-14	缝台下罩壳橡胶	Cushion Rubber	1	1	1	1
B-58	209-03-23	缝台下罩壳限位片	Latch	1	1	1	1
B-59	2316-02-20	缝台下罩壳限位片架	Plate	1	1	1	1
B-60	12-10400820-01	缝台下罩壳限位片架螺钉	Screw M4x8	2	2	2	2
B-61	2316-02-37	机针硅油盒盖	Cover	1	1	1	1
B-62	2316-02-36	机针硅油盒	Silicone Oil Reservoir(lower)	1	1	1	1
B-63	12-40401225-01	机针硅油盒固定组合螺钉	Screw M4x0.7	1	1	1	1
B-64	2316-02-38	机针硅油盒供油管夹	Delivery Pipe Clamp	2	2	2	2
B-65	2316-02-39-02	机针硅油盒供油管	For Tubing	1	1	1	1
B-66	2316-02-39-01	机针硅油盒供油管油线	Oil Line	1	1	1	1
B-67	2316-02-40	机针硅油冷却架下堵塞	Frame The Jam	1	1	1	1
B-68	2316-02-39	机针硅油冷却架	Needle Thread Lubrication	1	1		
B-68A	2316-02-39A	机针硅油冷却架	Needle Thread Lubrication			1	1
B-69	12-40401225-01	机针硅油冷却架螺钉	Screw M4x12	2	2	2	2
B-70	279-09-20	机针硅油冷却毡固定针	Fixed Needle	1	1	1	1
B-71	2316-02-41	机针硅油冷却毡	Oil Felt 10x7x15	1	1	1	1
B-72	000020001	型号牌	Type Plate	1	1	1	1
B-73	101-01-14	型号牌铆钉	Rivet	2	2	2	2

C. 主轴驱动部件 Crank Shaft Drive Mechanism

序号 NO.	图号 REF NO.	名称	DESCRIPTION	数量 AMT			
				3线	4线	5线	5H
C-1	2319-01-24	主轴	Crank Shaft	1			
	2319-01-24A	主轴	Crank Shaft		1		
	2319-01-24B	主轴	Crank Shaft			1	
	2319-01-24C	主轴	Crank Shaft				1
C-2	2316-03-02	主轴平衡块	Balance Weight	2	2	2	2
C-3	12-40300825-01	主轴平衡块螺钉	Screw M3x8	4	4	4	4
C-4	2316-03-03	主轴油量销	Pin	1	1	1	1
C-5	2316-03-04	主轴前端螺钉	Screw M6x8	1	1		
C-5A	209-04-09	五线主轴接轴	Shaft Joint Shaft			1	1
C-6	2316-03-05	主轴左轴承密封盖	Sealed Cap T=2.5	1	1		
C-6A	2316-03-05A	五线主轴左轴承密封盖	Sealed Cap T=2.5			1	1
C-7	12-40400825-01	主轴左轴承密封盖螺钉	Screw M4x8	3	3		
C-7A	12-10401020-01	主轴左轴承密封盖螺钉	Screw M4x10			2	2
C-7B	12-60401020-01	主轴左轴承密封盖螺钉	Screw M4x10			1	1
C-8	31-40020000-09	主轴左轴承O型圈	O Ring	1	1	1	1
C-9	2316-03-06	主轴左轴承组件	Ball Bearing Ass'y	1	1	1	1
C-9-1	2316-03-06-01	主轴左轴承	Ball Bearing 6202LB	(1)	(1)	(1)	(1)
C-9-2	2316-03-06-02	主轴左轴承轴套	Gear	(1)	(1)	(1)	(1)
C-9-3	12-80501012-01	主轴左轴承套螺钉	Screw M5x10	(1)	(1)	(1)	(1)
C-9-4	12-80500512-01	主轴左轴承轴套螺钉	Screw M5x5	(1)	(1)	(1)	(1)
C-9-5	31-30012000-09	主轴前轴承O型圈	O Ring	(2)	(2)	(2)	(2)
C-10	2316-03-17	主轴中轴承卡簧	Spring	1	1	1	1
C-11	2316-03-07	主轴中轴承	Ball Bearing 6203	2	2	2	2
C-13	2316-03-16	主轴弹性垫圈	Washer	1	1	1	1
C-14	279-02-06	主轴封油螺旋圈	Oil Seal	1	1	1	1
C-15	31-17017000-09	主轴封油螺旋圈O型圈	O Ring	1	1	1	1
C-16	31-40020000-09	主轴后轴承盖O型圈	O Ring	1	1	1	1
C-17	2316-03-09	主轴后轴承盖	Right Cover	1	1	1	1
C-18	12-40401025-01	主轴后轴承盖螺钉	Screw M4x12	3	3	3	3
C-19	2316-03-14	主轴铜套	Middle Bush for Crank Shaft Center	1	1	1	1

D.过线夹线部件 Thread Tension Mechanism

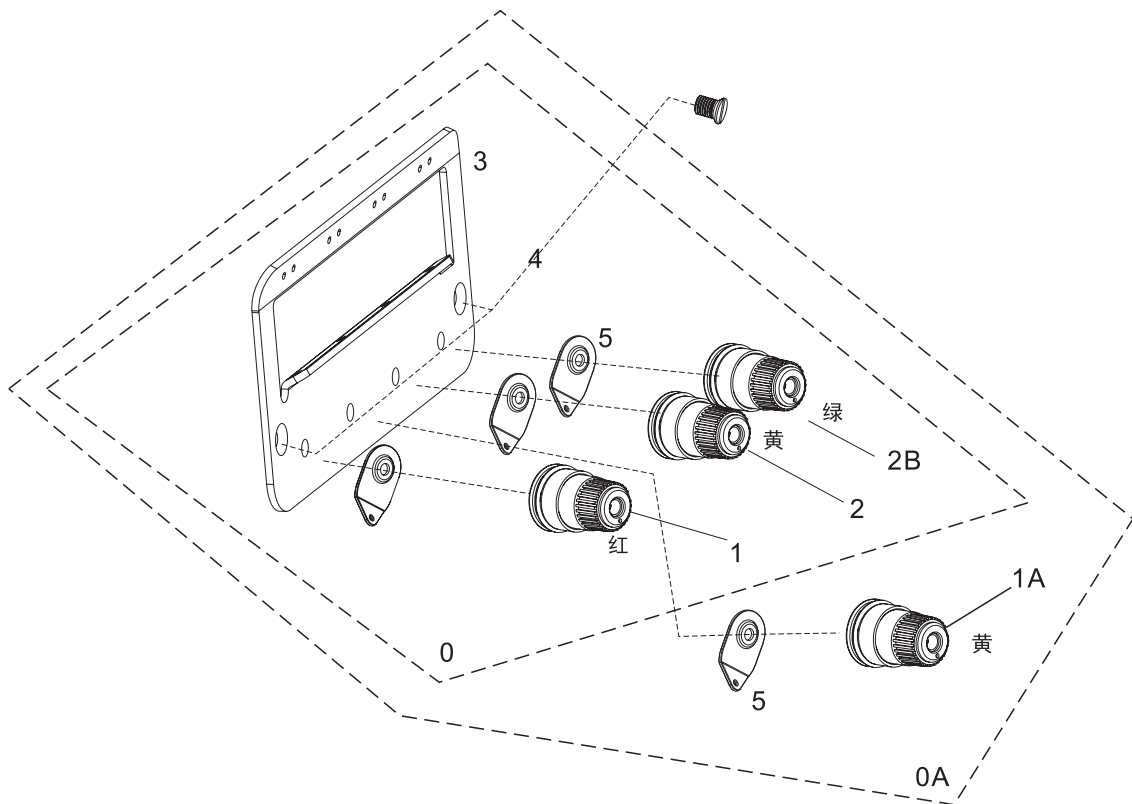
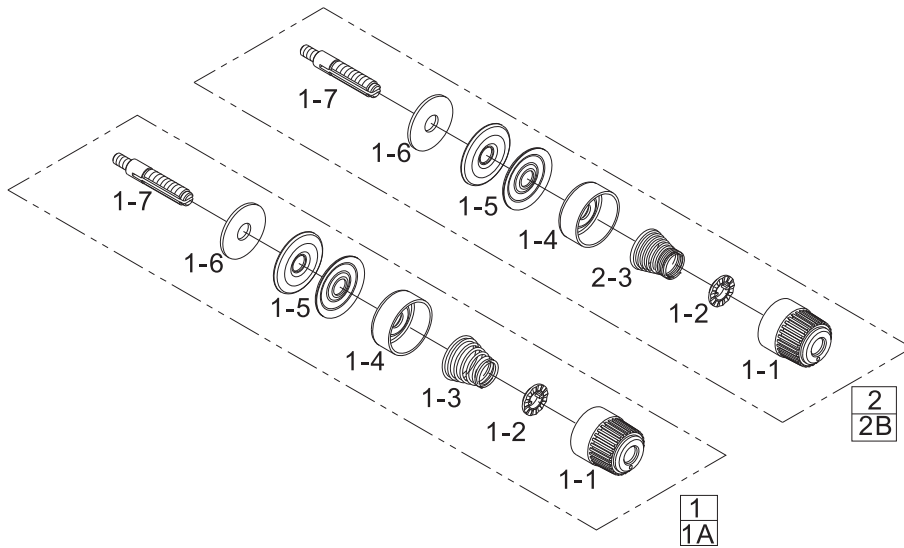

D.过线夹线部件 Thread Tension Mechanism

序号 NO.	图号 REF NO.	名称	DESCRIPTION	数量 AMT			
				3线	4线	5线	5H
D-0	2319-01-12	三线夹线器大组件	Three - Wire Clamp Assembly	1			
D-0A	2319-01-12A	四五线夹线器大组件	Four, Five Wire Clamp Wire Assembly		1	1	1
D-1	2316-04-01A	面线夹线器组件(红点)	Thread Tension Device Assembly	(1)	(1)	(1)	(1)
D-1A	2316-04-01B	面线夹线器组件(黄点)	Thread Tension Device Assembly		(1)	(1)	(1)
D-2	2316-04-01C	底线夹线器组件(黄点)	Thread Tension Device Assembly	(1)	(1)	(1)	(1)
D-2A	2316-04-01D	底线夹线器组件(绿点)	Thread Tension Device Assembly	(1)	(1)	(1)	(1)
D-1-1	2316-04-01-01	压线螺母组件	Thread Tension Spring Cap Ass'y	(3)	(4)	(4)	(4)
D-1-2	2316-04-01-02	压线定位圈	Stopper For Tension Spring	(3)	(4)	(4)	(4)
D-1-3	2316-04-01-03	压线簧	Thread Tension Spring-needle	(1)	(2)	(2)	(2)
D-2-3	2316-04-01-03C	压线簧	Thread Tension Spring-looper	(2)	(2)	(2)	(2)
D-1-4	2316-04-01-04	压线簧座套	Retainer For Thread Tension Spring	(3)	(4)	(4)	(4)
D-1-5	2316-04-01-05	夹线板	Tension Disc	(6)	(8)	(8)	(8)
D-1-6	2316-04-01-06	夹线板毡垫	Felt For Thread Tension Device	(3)	(1)	(4)	(4)
D-1-7	2316-04-01-07	夹线螺钉	Thread Tension Post	(3)	(4)	(4)	(4)
D-3	2319-01-12	夹线器支架过线板	Thread Guide	(1)	(1)	(1)	(1)
D-4	12-10400820-01	夹线器支架过线板螺钉	Screw M4x8	(2)	(2)	(2)	(2)
D-5	2316-04-04	夹线器过线板	Tension Guide	(4)	(4)	(4)	(4)

E. 过线挑线部件 Thread Guide & Thead Take-Up Mechanism

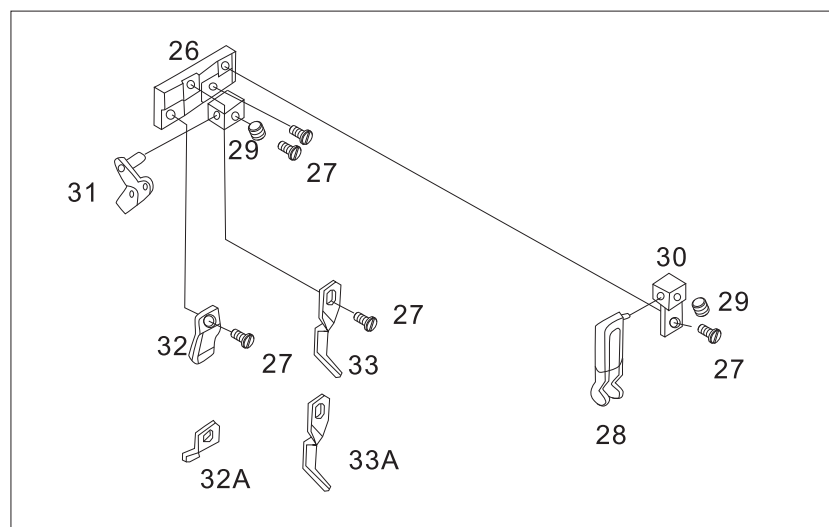
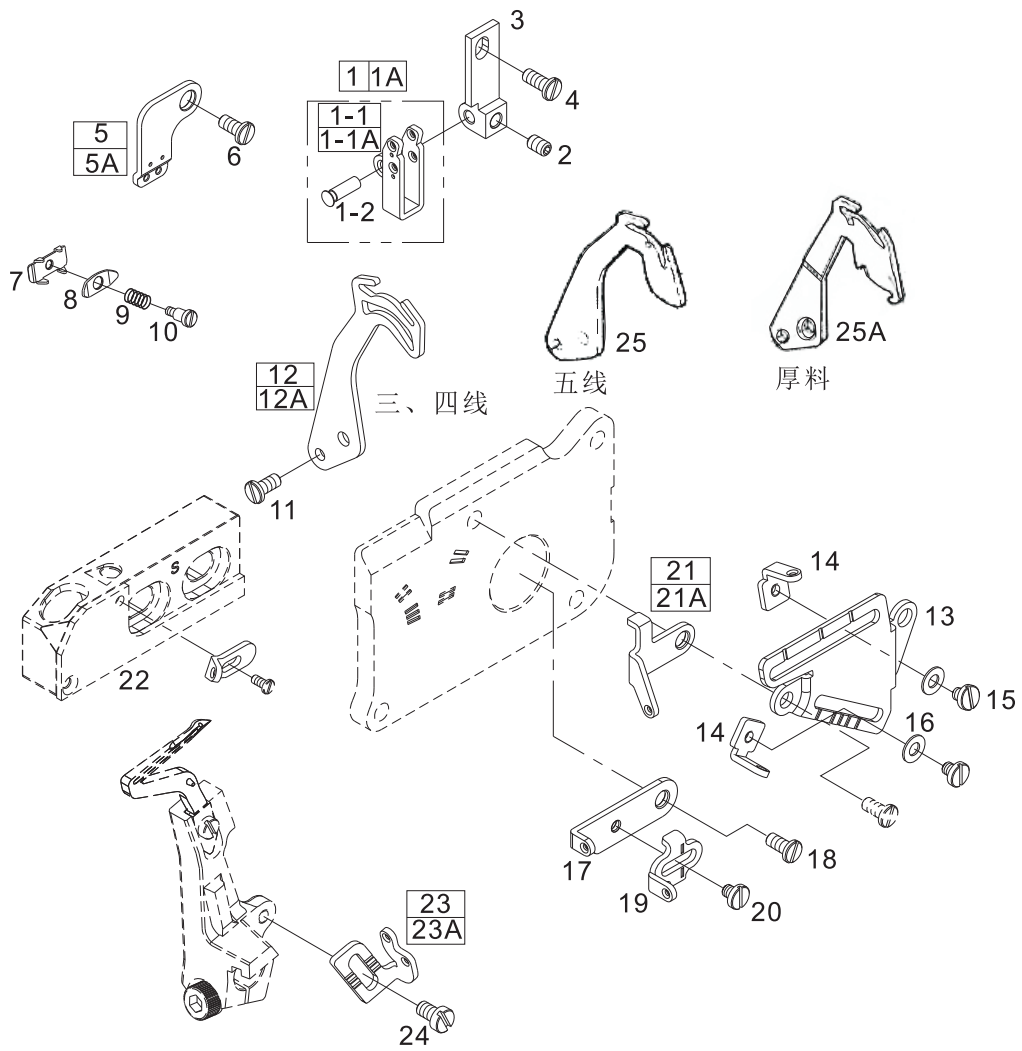

五线

E.过线挑线部件 Thread Guide & Thead Take-Up Mechanism

序号 NO.	图号 REF NO.	名称	DESCRIPTION	数量 AMT			
				3线	4线	5线	5H
E-1	2316-05-01	四线上挑线过线板组件	Thread Guide Ass'y		1		
E-1A	2316-05-01A	三线上挑线过线板组件	Thread Guide Ass'y	1			
E-1-1	2316-05-01-01	四线上挑线过线板	Thread Guide		(1)		
E-1-1A	2316-05-01-01A	三线上挑线过线板	Thread Guide	(1)			
E-1-2	2316-05-01-02	上挑线过线板销	Pin	(1)	(1)		
E-2	12-80400412-01	上挑线过线板销紧固螺钉	Screw M4x4	1	1		
E-3	2316-05-02	上挑线过线板支架	Thread Guide Holder	1	1		
E-4	12-40400825-01	上挑线过线板销夹螺钉	Screw M4x8	1	1		
E-5	2316-05-03	四线针杆过线板	Thread Guide		1		
E-5A	2316-05-03A	三线针杆过线板	Thread guide	1			
E-6	12-40400525-01	针杆过线板螺钉	Screw M4x8	1	1		
E-7	2316-05-04	针夹轧头夹线板	Thread Retainer Bracket	1	1	1	1
E-8	2316-05-05	针夹轧头压线板	Thread Retainer	1	1	1	1
E-9	2316-05-06	针夹轧头压线簧	Thread Retainer Spring	1	1	1	1
E-10	2316-05-07	针夹轧头夹线板螺钉	Screw M2xP0.4xL3.2	1	1	1	1
E-11	12-40300625-01	面线上挑线板螺钉	Screw M3x6	2	2	2	2
E-12	2316-05-08	三线面线上挑线板	Needle Thread Take Up	1			
E-12A	2316-05-08A	四线面线上挑线板	Needle Thread Take Up		1		
E-13	2316-05-09	上下弯针过线架板	Thread Guide Bracket-Looper	1	1	1	1
E-14	279-03-22	上下弯针过线调节勾	Thread Guide	2	2	2	2
E-15	11-40080425-01D	上下弯针过线调节勾螺钉	Screw M3x4	2	2	2	2
E-16	21-03405070-01	上下弯针过线调节垫圈	Washer	2	2	2	2
E-17	2316-05-11	上弯针轴挑线板	Looper Thread Take Up	1	1	1	1
E-18	12-40400825-01	上弯针轴挑线板螺钉	Screw M4x8	1	1	1	1
E-19	2316-05-12	下弯针挑线板	Thread Guide	1	1	1	1
E-20	12-60300320-01	下弯针挑线板螺钉	Screw M3x3	1	1	1	1
E-21	2316-05-13	上弯针下过线勾	Thread Guide	1	1		
E-21A	2316-05-13A	上弯针下过线勾	Thread Guide			1	1
E-22	2316-05-14	上弯针上过线勾	Thread Guide	1	1	1	1
E-23	2316-05-15	下弯针架挑线板	Looper Thread Take Up	1	1		
E-23A	2316-05-15A	下弯针架挑线板	Looper Thread Take Up			1	1
E-24	12-60350620-01	下弯针架挑线板螺钉	Screw M3.5x6	1	1	1	1
E-25	2316-05-16	五线面线上挑线板	Pick Line Board On			1	
E-25A	2316-05-16A	五线厚料面线上挑线板	Pick Line Board On				1
E-26	2316-05-17	挑线过线支座	Pick Line After Line Support			1	1
E-27	12-40400825-01	挑线过线支座螺钉	Screw M4x7.5			5	5
E-28	2316-05-18	挑线上过线组件	Pick A Winding A Line			1	1
E-29	12-80400412-01	挑线过线螺钉	Screw M4x4			2	2
E-30	2316-05-19	挑线上过线支架	Pick A Line Support Online			1	1
E-31	2316-05-20	挑线下过线	Pick Offine Thread			1	1
E-32	2316-05-21	机针上过线	Machine Needle On Line			1	
E-32A	2316-05-21A	机针下过线(厚料)	Machine Needle On Line				1
E-33	2316-05-22	机针上过线	Machine Needle Thread Under			1	
E-33A	2316-05-22A	机针下过线(厚料)	Machine Needle Thread Under				1

F. 针杆部件 Needle Mechanism

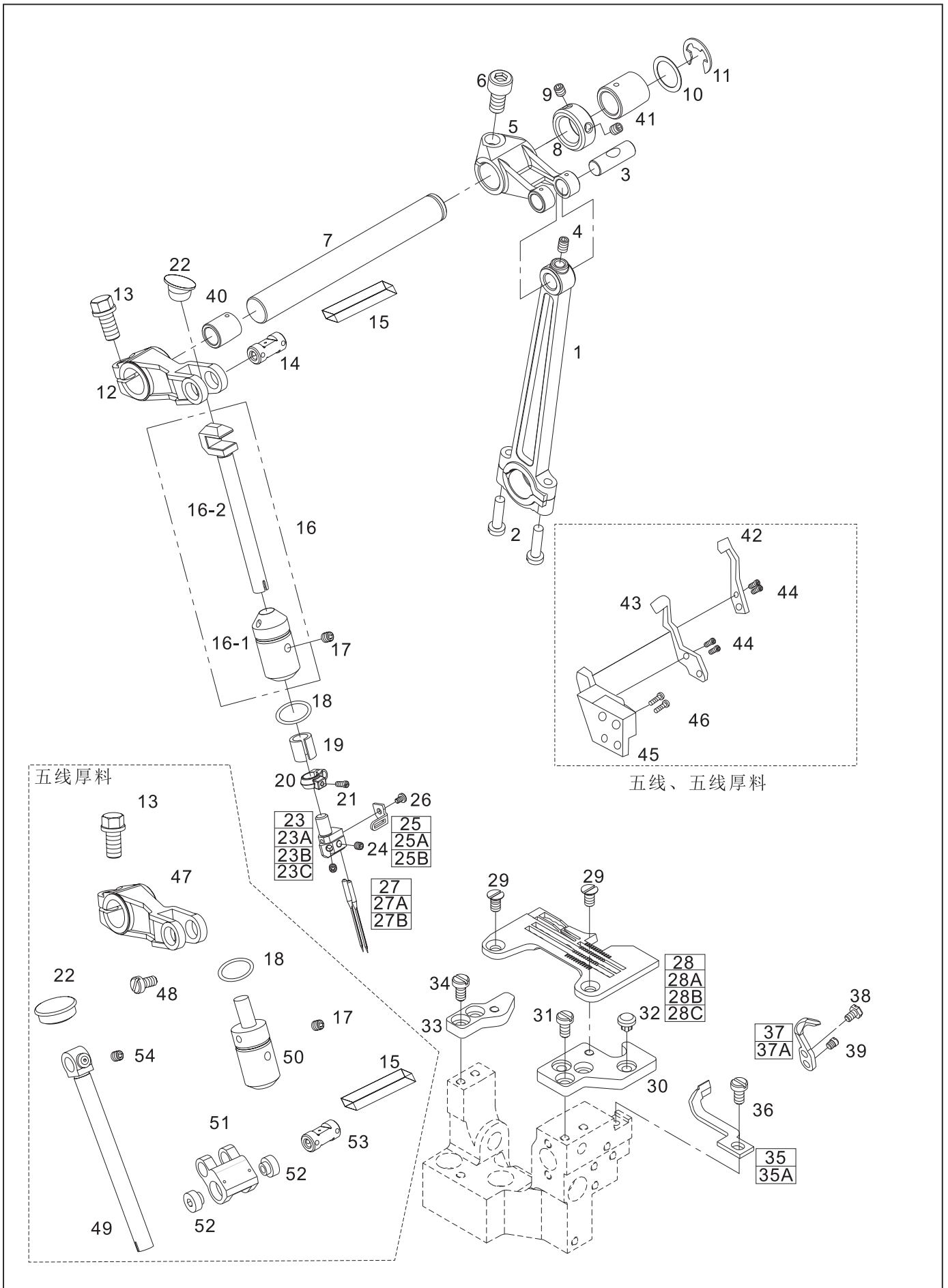

F. 针杆部件 Needle Mechanism

序号 NO.	图号 REF NO.	名称	DESCRIPTION	数量 AMT			
				3线	4线	5线	5H
F-1	2316-06-01	针杆摆动连杆	Needle Bar Swinging Rod	1	1	1	1
F-2	12-40401625-01	针杆摆动连杆螺钉	Screw M4x16	2	2	2	2
F-3	209-05-19	针杆摆动连杆销	Pin	1	1	1	1
F-4	12-80400612-01	针杆摆动连杆销螺钉	Screw M4x6	1	1	1	1
F-5	2316-06-02	针杆摆动连杆曲柄	Crank	1	1	1	1
F-6	12-65601222-01	针杆摆动曲柄夹紧螺钉	Bolt	1	1	1	1
F-7	2316-06-03	针杆摆动轴	Shaft	1	1	1	1
F-8	2316-06-04	针杆摆动曲柄紧圈	Collar	1	1	1	1
F-9	12-80400412-01	针杆摆动曲柄紧圈螺钉	Screw M4x4	2	2	2	2
F-10	209-05-09	针杆摆动轴右轴套垫圈	Washer	1	1	1	1
F-11	24-08000000-09	针杆摆动轴开口挡圈	Open Ring E8	1	1	1	1
F-12	2316-06-07	针杆摆动曲柄	Lever	1	1	1	1
F-13	2316-06-32	针杆摆动曲柄夹紧螺钉	Bolt	1	1	1	1
F-14	2316-06-08	针杆摆动曲柄销	Pin	1	1	1	1
F-15	2316-06-07-01	针杆摆动曲柄销油线	Oil Line	1	1	1	1
F-16	2316-06-09	针杆组件	Needle Bar Component	1	1	1	1
F-16-1	2316-06-09-01	针杆下轴套	Needle Bar Under The Bush	1	1	1	1
F-16-2	2316-06-09-02	针杆	Needle Bar	1	1	1	1
F-17	12-80400542-01	针杆下轴套紧固螺钉	Screw M4x5	1	1	1	1
F-18	31-11515000-09	针杆下轴套O型圈	O Ring	1	1	1	1
F-19	2316-06-10	针夹轧头圈	Felt	1	1	1	1
F-20	2316-06-11	针夹轧头	Holder	1	1	1	1
F-21	12-60300620-01	针夹轧头夹紧螺钉	Screw M3x6	1	1	1	1
F-22	2319-01-32	针杆孔上橡皮塞	Plug	1	1	1	1
F-23	2316-06-12	三线针夹	Needle Holder Assy.	1			
F-23A	2316-06-12A	四线针夹	Needle Holder Assy.		1		
F-23B	2316-06-12B	五线针夹	Needle Holder Assy.			1	
F-23C	2316-06-12C	五线厚料针夹	Needle Holder Assy.				1
F-24	12-80300312-01	支针螺钉	Screw M3x3	1	2	2	2
F-25	2316-06-13	五线针夹导线板	Thread Guide			1	1
F-25A	2316-06-13A	四线针夹导线板	Thread Guide		1		
F-25B	2316-06-13B	三线针夹导线板	Thread Guide	1			
F-26	12-60200320-01	针夹导线板螺钉	Screw M2x3	1	1	1	1
F-27	279-02-30	机针DC*27 #11	Needle	1	2		
F-27A	279-02-30A	机针DC*27 #14	Needle			2	
F-27B	206-02-08	机针DC*27 #18	Needle				2
F-28	2316-06-14	三线针板	Needle plate	1			
F-28A	2316-06-14A	四线针板	Needle plate		1		
F-28B	2316-06-14B	五线针板	Needle plate			1	
F-28C	2316-06-14C	五线厚料针板	Needle plate				1
F-29	12-10400720-01	针板螺钉	Screw M4x5	2	2	2	2
F-30	2316-06-15	前针板垫	Bracket (Font)	1	1	1	1
F-31	12-40400525-01	前针板垫螺钉	Screw M4x5	2	2	2	2
F-32	209-03-14	针板垫橡胶缓冲塞	Cushion Rubber	2	2	2	2
F-33	2316-06-16	后针板垫	Bracket (Rear)	1	1	1	1
F-34	12-40400825-01	后针板垫螺钉	Screw M4x8	2	2	2	2
F-35	2316-06-17	三四线机针前护针	Needle Guard (Front)	1	1		
F-35A	2316-06-17A	五线机针前护针	Needle Guard			1	1
F-36	12-40400525-01	机针前护针螺钉	Screw M4x8	1	1	1	1
F-37	2316-06-18	三四线机针后护针	Needle Guard (Rear)	1	1		
F-37A	2316-06-18A	五线机针后护针	Needle Guard			1	1
F-38	12-90300520-01	机针后保针板螺钉	Bolt M3x5	1	1	1	1
F-39	2316-06-02	机针后保针板下螺钉	Screw M3x2.5	1	1	1	1
F-40	2316-06-19	针杆摆动轴左轴套	Front Bush for Driving Needle Bar	1	1	1	1
F-41	2316-06-20	针杆摆动轴右轴套	Rear Bush for Driving Needle Bar	1	1	1	1
F-42	2316-06-22	链线前护针	Chain Line Apron Pin			1	1
F-43	2316-06-23	链线后护针	Chain Line Guard Needle			1	1
F-44	12-00300620-01	链线护针螺钉	Screw M3x6			4	4
F-45	2316-06-24	链线护针托架	Bracket			1	1

F. 针杆部件 Needle Mechanism

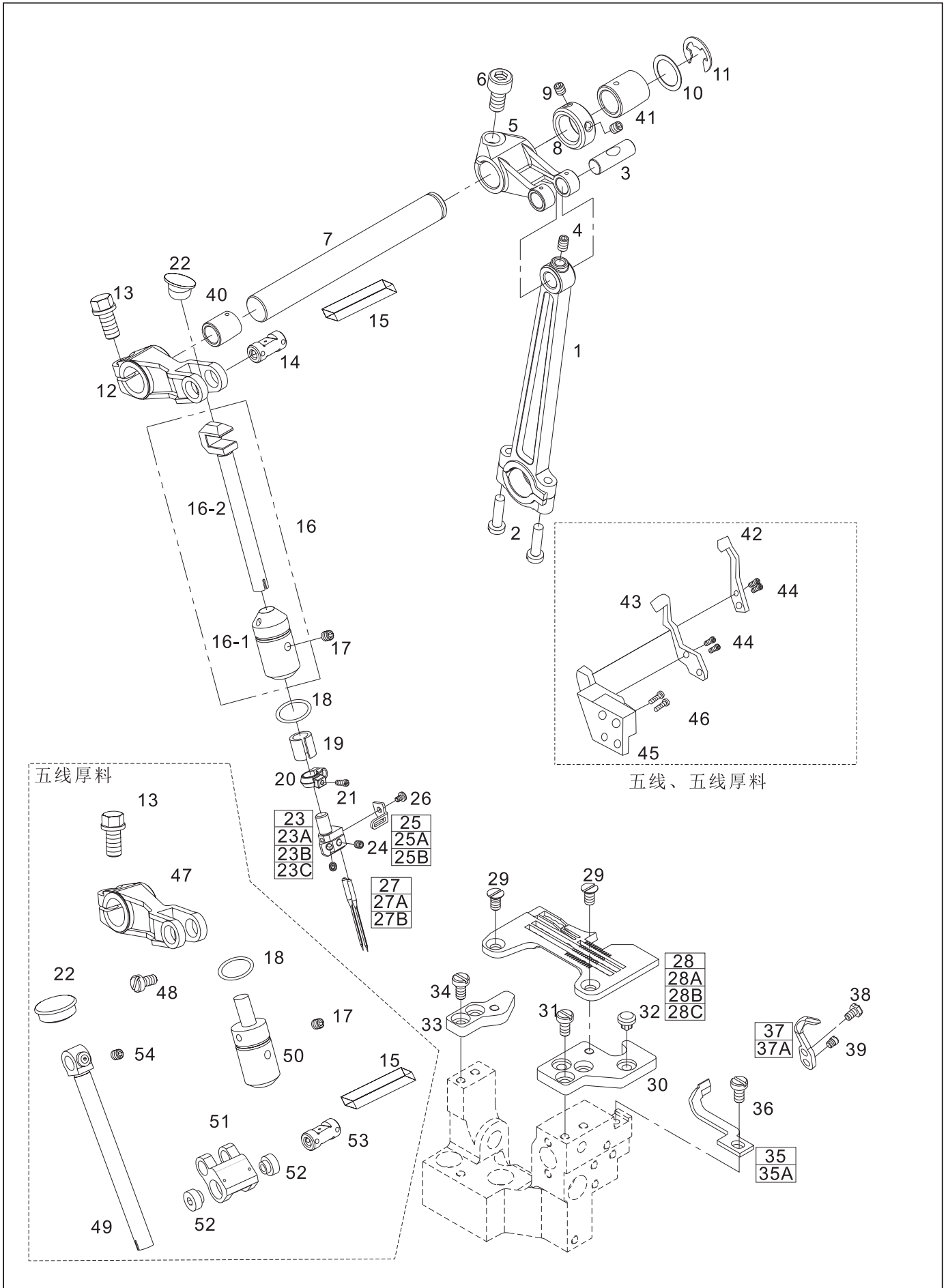

F.针杆部件 Needle Mechanism

序号 NO.	图号 REF NO.	名称	DESCRIPTION	数量 AMT			
				3线	4线	5线	5H
F-46	12-60401020-01	链线护针托架螺钉	Screw M4x10			2	2
F-47	2316-06-25	厚料针杆曲柄	Crank				1
F-48	2316-06-26	厚料针杆曲柄销轴螺钉	Screw M3x4				2
F-49	2316-06-27	厚料针杆	Thick Needle Bar				1
F-50	2316-06-28	厚料针杆下套	Cover				1
F-51	2316-06-29	厚料连接曲柄	Pin				1
F-52	2316-06-30	针杆曲柄短连接销	Pin				2
F-53	2316-06-31	针杆连接销	Pin				1
F-54	12-80300312-01	针杆螺钉	Screw M3X3				1

G .上弯针部件 Upper Loper Driver Mechaniam

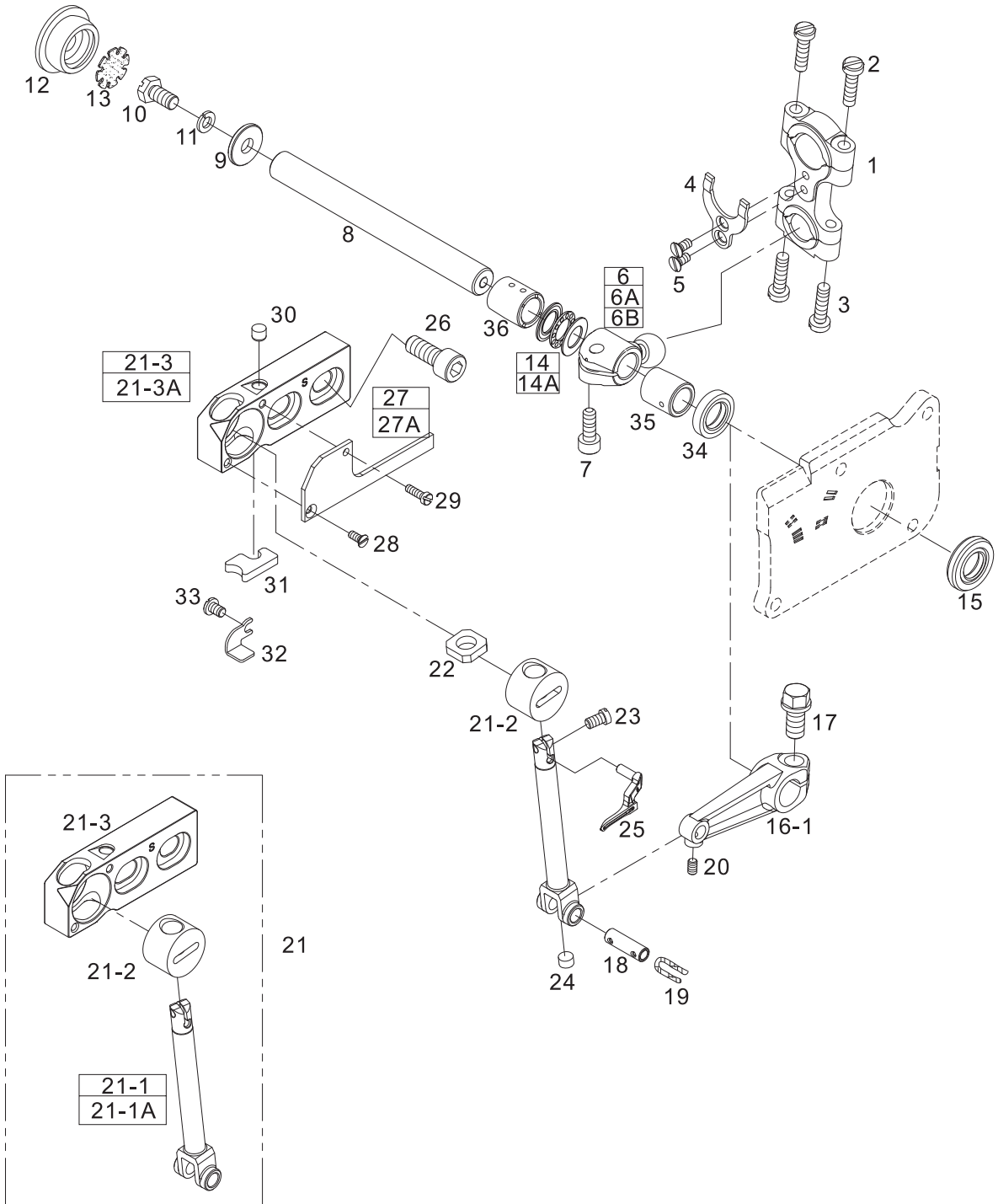

G.上弯针部件 Upper Looper Driver Mechaniam

序号 NO.	图号 REF NO.	名称	DESCRIPTION	数量 AMT			
				3线	4线	5线	5H
G-1	2316-07-01	上弯针连杆	Bent Pin Connecting Rod	(1)	(1)	(1)	(1)
G-2	12-60401620-01	上弯针连杆螺钉	Screw M4x16	(2)	(2)	(2)	(2)
G-3	12-60401620-01	上弯针连杆螺钉	Screw M4x16	(2)	(2)	(2)	(2)
G-4	2316-07-02	上弯针连杆止摆块	Check Pendulum Block	(1)	(1)	(1)	(1)
G-5	2316-07-03	上弯针连杆止摆块螺钉	Screw	(2)	(2)	(2)	(2)
G-6	2316-07-04	上弯针轴球曲柄	Crank	(1)	(1)		
G-6A	2316-07-04A	上弯针轴球曲柄	Crank			(1)	
G-6B	2316-07-04B	厚料上弯针轴球曲柄	Crank				(1)
G-7	12-65601222-01	上弯针轴球曲柄夹紧螺钉	Bolt M6x12	1	1	1	1
G-8	2316-07-05	上弯针轴	Shaft	1	1	1	1
G-9	21-05420144-02	上弯针轴后端面垫圈	Washer	1	1	1	1
G-10	12-90501020-01	上弯针轴后端面螺钉	Bolt	1	1	1	1
G-11	22-04000000-08	上弯针轴后端面弹簧垫圈	Spring Washer	1	1	1	1
G-12	2316-07-07	上弯针轴后橡皮塞	Plug	1	1	1	1
G-13	2316-07-08	上弯针轴后过滤板	Filter	1	1	1	1
G-14	2316-07-39	四线上弯针轴承	Spacer		1		1
G-14A	2316-07-39A	三五线上弯针轴承	Spacer	1		1	
G-15	32-09440190-09	上弯针前密封板油封	Oil Seal	1	1	1	1
G-16	2316-07-15-00	上弯针滑块导架组件	Upper Bend Needle Slider Guide Frame Assembly	1	1	1	1
G-16-1	2316-07-11	上弯针轴曲柄	Lever	(1)	(1)	(1)	(1)
G-17	2316-06-32	上弯针轴曲柄夹紧螺钉	Bolt M6x12	1	1	1	1
G-18	2316-07-12	上弯针摇杆销	Pin Assy	(1)	(1)	(1)	(1)
G-19	2316-07-15-01	上弯针摇杆销油线	Oil Line	1	1	1	1
G-20	12-80300412-01	上弯针摇杆销紧固螺钉	Screw M3x4	(1)	(1)	(1)	(1)
G-21	2316-07-13-00	上弯针导架座组件	Guide Seat Components	(1)	(1)	(1)	(1)
G-21-1	2316-07-13	上弯针摇杆	Upper Looper Holder	(1)	(1)	(1)	
G-21-1A	2316-07-13A	厚料上弯针摇杆	Upper Looper Holder				(1)
G-21-2	2316-07-14	上弯针摇杆支点滑套	Rocker Support Sliding Sleeve	(1)			
G-21-3	2316-07-15	上弯针导架座	Upper Looper Holder Base	(1)	(1)	(1)	
G-21-3A	2316-07-15A	上弯针导架座	Upper Looper Holder Base				(1)
G-22	209-07-15	上弯针摇杆支点滑套毡垫	Felt	(1)	(1)	(1)	(1)
G-23	12-60350620-01	上弯针夹紧螺钉	Screw M3.5x6	1	1	1	1
G-24	2316-07-16	上弯针摇杆塞	Needle Rocker Plug	1	1	1	1
G-25	2316-07-17	上弯针	Upper Looper	1	1	1	
	2316-07-17C	上弯针	Upper Looper				1
G-26	12-60601522-01	上弯针导架座螺钉	Screw M6x15	2	2	2	2
G-27	2316-07-19	上弯针导架座挡板	Cover	(1)	(1)	(1)	
G-27A	2316-07-19A	上弯针导架座挡板	Cover				(1)
G-28	12-10250620-01	上弯针导架座挡板短螺钉	Screw M2.5x6	(1)	(1)	(1)	(1)
G-29	12-60250620-01	上弯针导架座挡板长螺钉	Screw M3.5x6	(1)	(1)	(1)	(1)
G-30	2316-07-20	上弯针导架座油塞	Plug	1	1	1	1
G-31	2316-07-21	上弯针导架座下油毡	Felt	1	1	1	1
G-32	2316-07-22	导架座下油毡固定板	Bracket	1	1	1	1
G-33	12-60300420-01A	导架座下油毡固定板螺钉	Screw M3x4	1	1	1	1
G-34	32-10030150-09	上弯针轴前轴套油封	Oil Seal	1	1	1	1
G-35	2316-07-24	上弯针轴前轴套	Shaft	1	1	1	1
G-36	2316-07-25	上弯针轴后轴套	Shaft	1	1	1	1

H. 下弯针部件 Lower Looper Driver Mechaniam

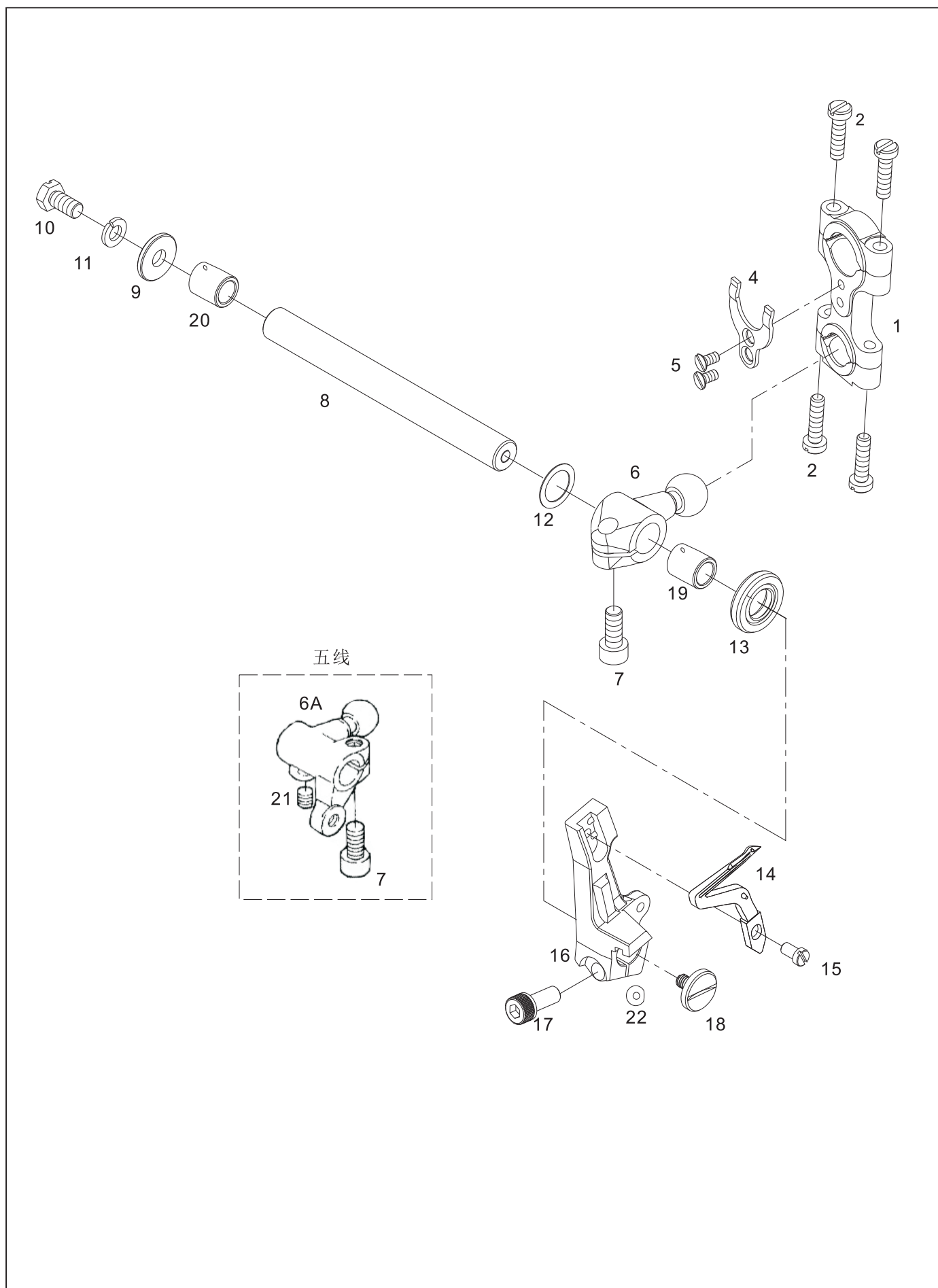

H.下弯针部件 Lower Looper Driver Mechaniam

序号 NO.	图号 REF NO.	名称	DESCRIPTION	数量 AMT			
				3线	4线	5线	5H
H-1	2316-07-01	下弯针连杆	Lower Looper Connecting Rod	(1)	(1)	(1)	(1)
H-2	12-60401620-01	下弯针连杆螺钉	Screw M4x16	(4)	(4)	(4)	(4)
H-4	2316-07-02	下弯针连杆止摆块	Check Pendulum Block	(1)	(1)	(1)	(1)
H-5	2316-07-03	下弯针连杆止摆块螺钉	Screw M3x6	(2)	(2)	(2)	(2)
H-6	2316-08-01	下弯针轴球曲柄	Crank	(1)	(1)		
H-6A	2316-08-01A	五线下弯针轴球曲柄	Crank			(1)	(1)
H-7	12-65601222-01	下弯针轴球曲柄夹紧螺钉	Bolt M6x12	(1)	(1)	(1)	(1)
H-8	2316-07-05	下弯针轴	Shaft	1	1	1	1
H-9	21-05420144-02	下弯针轴后端面垫圈	Washer	1	1	1	1
H-10	12-90501020-01	下弯针轴后端面螺钉	Bolt M5x10	1	1	1	1
H-11	22-04000000-08	下弯针轴后端面弹簧垫圈	Spring Washer	1	1	1	1
H-12	2316-08-07	上弯针轴垫圈	Washer	1	1	1	1
H-13	32-10070190-09	下弯针前轴套油封	Oil Seal	1	1	1	1
H-14	2316-08-02	三五线下弯针	Lower Looper	1		1	1
	2316-08-02A	四线下弯针	Lower Looper		1		
H-15	12-60350620-01	下弯针紧固螺钉	Bolt M3.5x6	1	1	1	1
H-16	2316-08-03	下弯针架	Lower Looper Holder Assy.	1	1	1	1
H-17	2316-08-04	下弯针架夹紧螺钉	Bolt M5x12	1	1	1	1
H-18	2316-08-05	下弯针架吊紧螺钉	Screw M4x7	1	1	1	1
H-19	2316-07-24	下弯针前轴套	Shaft	1	1	1	1
H-20	2316-07-25	下弯针后轴套	Shaft	1	1	1	1
H-21	12-80500512-01	五线下弯针轴球曲柄螺钉	Screw M5x5			1	1
H-22	2316-08-06	锁紧垫片	Spacer	1	1	1	1

I.前弯针部件 Chain Stitch Looper Mechanism

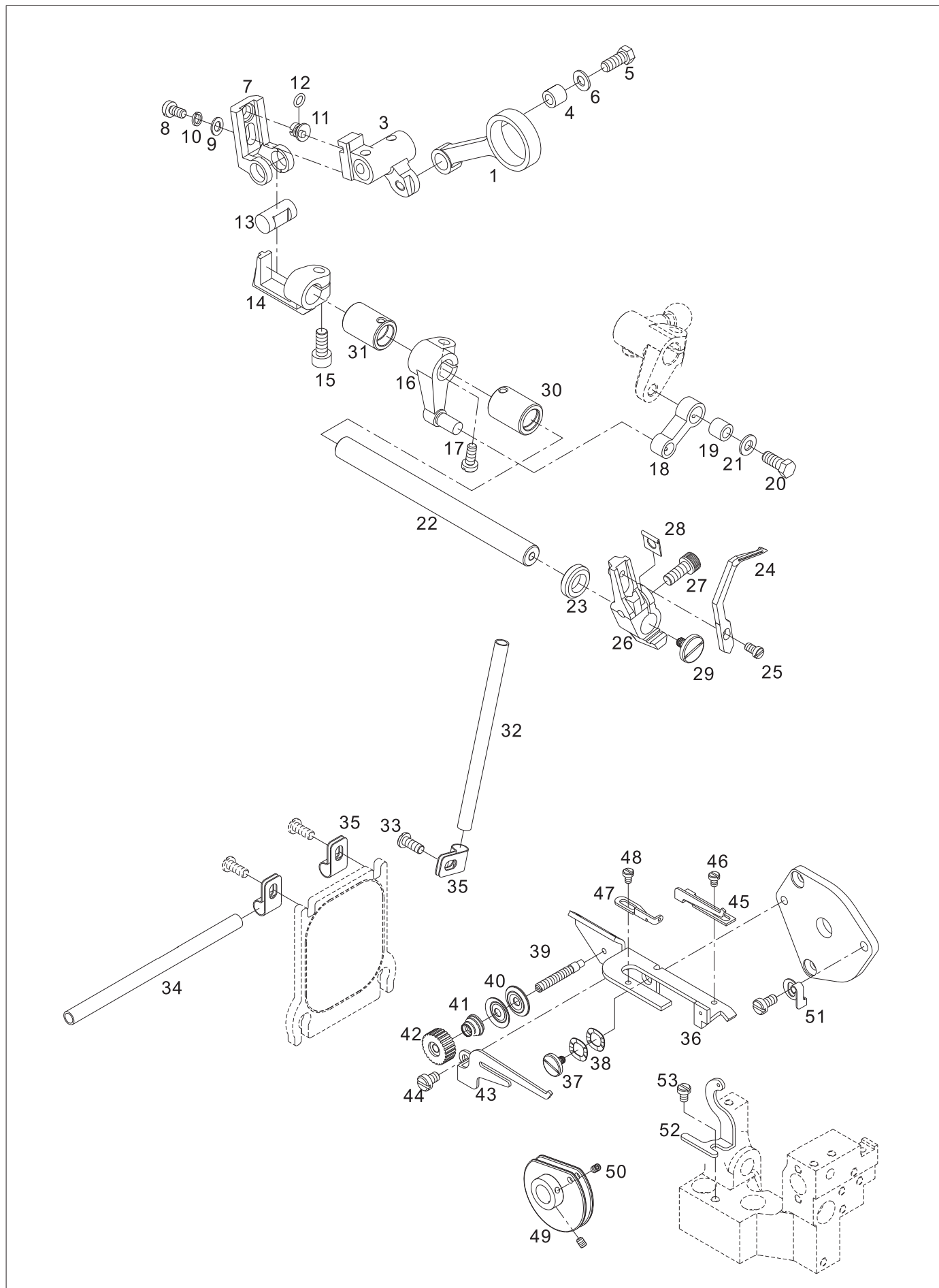

I.前弯针部件 Chain Stitch Looper Mechanism

序号 NO.	图号 REF NO.	名称	DESCRIPTION	数量 AMT			
				3线	4线	5线	5H
I-1	2316-09-01A	前弯针连杆	Looper Connection Rod			1	1
I-3	2316-09-02-00	前弯针架轴前后曲柄	Looper Slide Crank			1	1
I-4	2316-09-03	前弯针架轴左右连杆滚柱	Bushing			1	1
I-5	12-90501220-01	前弯针连杆滚柱螺钉	Screw M5x12			1	1
I-6	21-05111110-02	前弯针连杆垫圈	Washer			1	1
I-7	2316-09-04	前弯针架轴前后曲柄座	Looper Slide			1	1
I-8	12-60501222-01	前后曲柄座螺钉	Screw M5x12			1	1
I-9	21-05010110-01	前后曲柄座垫圈	Washer			1	1
I-10	22-05000000-09	前后曲柄座弹簧垫圈	Spring Washer			1	1
I-11	2316-09-05	前后曲柄座调节轴	Looper Adjustment Shaft			1	1
I-12	31-04001500-08	前后曲柄座调节轴O型圈	O-ring			1	1
I-13	209-18-07	前弯针架轴前后滚柱轴	Slide Shaft			(1)	(1)
I-14	2316-09-06	前弯针架轴前后调节座	Looper Slide Holder			(1)	(1)
I-15	12-65601222-01	前后曲柄座夹紧螺钉	Screw M6x12			(1)	(1)
I-16	2316-09-07	前弯针架轴左右曲柄	Looper Driving Crank			(1)	(1)
I-17	12-65601222-01	左右曲柄夹紧螺钉	Screw M6x12			(1)	(1)
I-18	2316-09-08	前弯针架轴左右连杆	Looper Connection Link			(1)	(1)
I-19	2316-09-03	前弯针架轴左右连杆滚柱	Bushing			(1)	(1)
I-20	12-90501323-01	前弯针架轴左右连杆螺钉	Screw M5x13			(1)	(1)
I-21	21-05111110-02	垫圈	Washer			(1)	(1)
I-22	2316-09-10	前弯针架轴	Looper Shaft			(1)	(1)
I-23	32-10030150-09	前弯针架轴前轴套油封	Looper Oil Seal			1	1
I-24	2316-09-12	前弯针	Looper			1	1
	2316-09-12C	前弯针	Looper			1	1
I-25	12-60350620-01	前弯针螺钉	Screw M3.5x6			1	1
I-26	2316-09-13	前弯针架	Looper Bracket			1	1
I-27	2316-08-04	前弯针架夹紧螺钉	Screw M5x12			1	1
I-28	2316-09-30	前弯针架夹紧螺钉垫片	Looper Bracket Spacer			1	1
I-29	2316-09-14	前弯针架吊紧螺钉	Screw M4x7			1	1
I-30	2316-07-24	前弯针架轴前轴套	Bushing			1	1
I-31	2316-07-25	前弯针架轴后轴套	Bushing			1	1
I-32	2316-09-17	前链线过线竖管	Thread Guide Bar A			1	1
I-33	12-40400825-01	前链线过线竖管夹螺钉	Screw M4x7.8			1	1
I-34	2316-09-18	前链线过线横管	Thread Guide Bar B			1	1
I-35	2316-09-19	前链线过线竖管夹	Thread Guide Holder			3	3
I-36	2316-09-20	打线凸轮夹线支架	Looper Thread Guide			(1)	(1)
I-37	209-03-13	打线凸轮夹线支架螺钉	Screw			1	1
I-38	23-06503110-09	弹簧垫片	Washer			2	2
I-39	2316-09-21	打线凸轮夹线螺钉	Thread Tension Shaft			(1)	(1)
I-40	2316-09-22	打线凸轮夹线板	Tension Disc			(2)	(2)
I-41	2316-09-23	打线凸轮压线簧	Tension Spring			(1)	(1)
I-42	2316-09-24	打线凸轮压线螺母组件	Thread Tension Nut Ass'y			(1)	(1)
I-43	2316-09-25	打线凸轮分线板	Looper Thread Guide A			1	1
I-44	12-60400520-01	打线凸轮分线板螺钉	Screw M4x5			1	1
I-45	2316-09-26	打线凸轮右过线勾	Looper Thread Guide B			1	1
I-46	12-60300420-01A	打线凸轮右过线勾螺钉	Screw M3x3.5			1	1
I-47	2316-09-27	打线凸轮左过线勾	Looper Thread Guide C			1	1
I-48	12-60300420-01A	打线凸轮左过线勾螺钉	Screw M3x3.5			1	1
I-49	2316-09-28	前弯针打线凸轮组件	Looper Cam Ass'y			1	1
I-50	12-80300312-01	打线凸轮套螺钉	Screw M3x3			2	2
I-51	209-19-06	打线凸轮夹线支架限位板	Thread Guide Plate Holder			1	1
I-52	2316-09-29	前链线过线勾	Looper Thread Guide D			1	1
I-53	12-40400825-01	前链线过线勾螺钉	Screw M4x7.8			1	1

J. 差动调节部件 Feed Mechanism

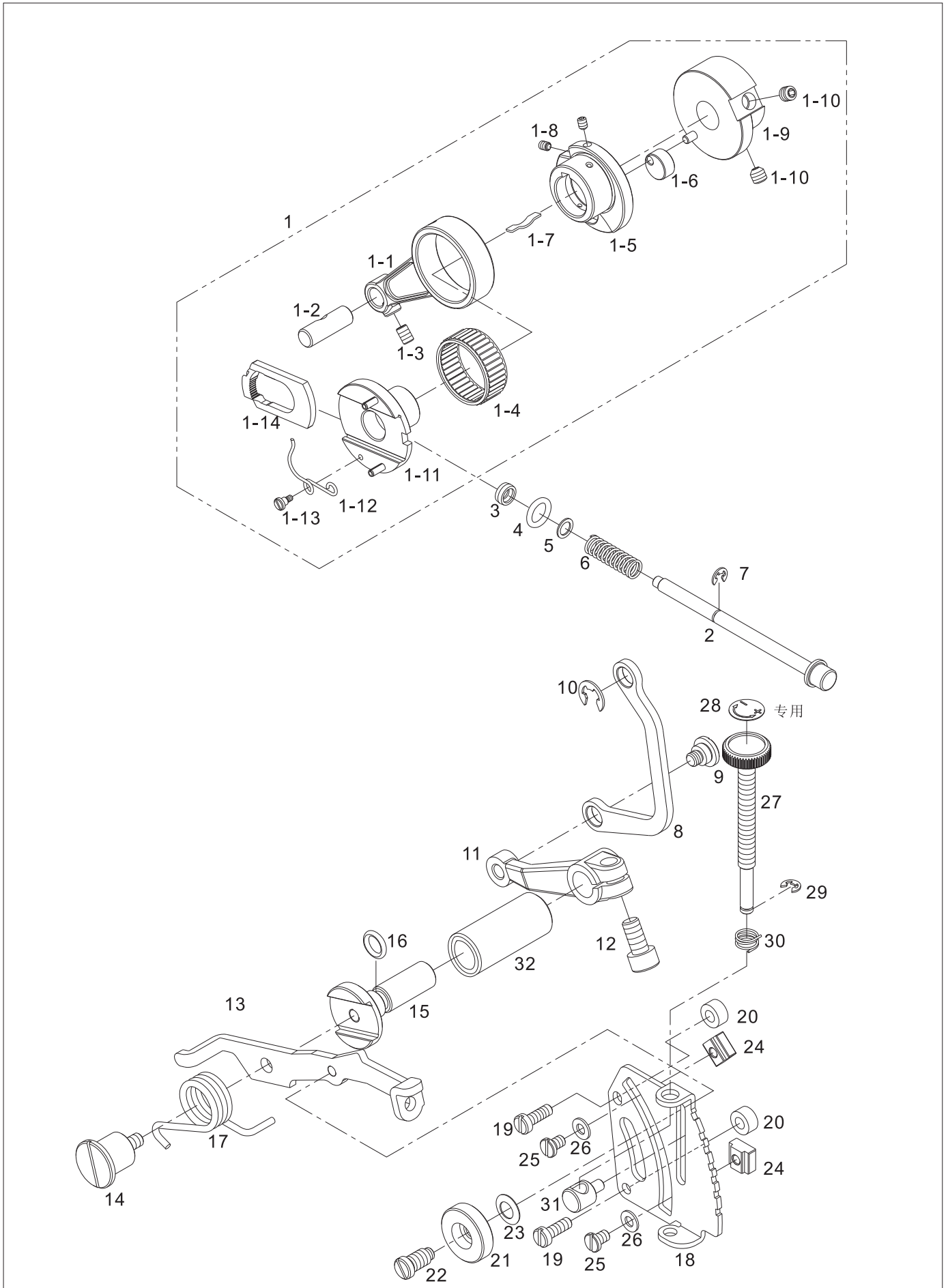

J.差动调节部件 Feed Mechanism

序号 NO.	图号 REF NO.	名称	DESCRIPTION	数量 AMT			
				3线	4线	5线	5H
J-1	2316-10-01	送布连杆组件	Feed Cam	1	1	1	1
J-1-1	2316-10-02	送布连杆	Connection	(1)	(1)	(1)	(1)
J-1-2	101-06-07	送布连杆销	Pin	(1)	(1)	(1)	(1)
J-1-3	12-80400612-01	送布连杆销紧固螺钉	Screw M4x6	(1)	(1)	(1)	(1)
J-1-4	2316-10-04	送布连杆滚针轴承	Needle Bearing	(1)	(1)	(1)	(1)
J-1-5	2316-10-05	送布凸轮	Eccentric Plate	(1)	(1)	(1)	(1)
J-1-6	2316-10-06	送布凸轮偏心滚柱	Guide(feed Eccentric)	(1)	(1)	(1)	(1)
J-1-7	2316-10-07	送布凸轮簧片	Flat Spring	(1)	(1)	(1)	(1)
J-1-8	2316-10-08	送布凸轮螺钉	Screw M3x4	(2)	(2)	(2)	(2)
J-1-9	2316-10-09	送布凸轮座组件	Regulator	(1)	(1)	(1)	(1)
J-1-10	12-80500512-01	送布凸轮座螺钉	Screw M5x5	(2)	(2)	(2)	(2)
J-1-11	2316-10-10	针距凸轮组件	Spring	(1)	(1)	(1)	(1)
J-1-12	2316-10-11	针距调节滑块锁紧簧	Spring	(2)	(2)	(2)	(2)
J-1-13	2316-10-12	针距调节滑块锁紧簧螺钉	Screw	(1)	(1)	(1)	(1)
J-1-14	2316-10-13	针距调节滑块	Slide Block	(1)	(1)	(1)	(1)
J-2	2316-10-14	针距调节杆	Push Button	1	1	1	1
J-3	2316-10-15	针距调节杆密封圈	Gasket	1	1	1	1
J-4	31-04013000-09	针距调节杆O型圈	O Ring	1	1	1	1
J-5	21-05505075-01	针距调节簧垫圈	Washer	1	1	1	1
J-6	2316-10-16	针距调节簧	Spring	1	1	1	1
J-7	24-03000000-08	针距调节杆开口挡圈	Ring E3	1	1	1	1
J-8	2316-10-17	差动调节曲柄拉杆	Link	1	1	1	1
J-9	209-09-30	差动调节曲柄拉杆轴位螺钉	Screw	1	1	1	1
J-10	24-06000000-08	差动调节曲柄拉杆开口挡圈	Ring E6	1	1	1	1
J-11	2316-10-18	差动板手调节曲柄	Lever	1	1	1	1
J-12	12-65601222-01	差动板手调节曲柄夹紧螺钉	Bolt	1	1	1	1
J-13	2316-10-19	差动板手	Lever	1	1	1	1
J-14	209-09-38	差动板手扭簧轴位螺钉	Screw	1	1	1	1
J-15	209-09-34	差动轴	Holder	1	1	1	1
J-16	31-06819000-09	差动轴O型圈	O Ring	1	1	1	1
J-17	209-09-37	差动板手扭簧	Spring	1	1	1	1
J-18	2316-10-20	差动板手座	Regulator Plate	1	1	1	1
J-19	12-40401225-01	差动板手座螺钉	Screw M4x12	2	2	2	2
J-20	2316-10-21	差动板手座塑料垫	Spacer	2	2	2	2
J-21	2316-10-22	差动板手锁紧螺母	Nut	1	1	1	1
J-22	2316-10-50	差动板手锁紧螺钉	Screw	1	1	1	1
J-23	23-06506140-09W	差动板手锁紧螺母碗形垫圈	Washer	1	1	1	1
J-24	2316-10-23	差动板手限位块	Stopper	2	2	2	2
J-25	12-10400720-01	差动板手限位块螺钉	Screw M4x8	2	2	2	2
J-26	2316-10-55	差动板手限位块垫圈	Washer	2	2	2	2
J-27	2316-10-24	差动板手微调螺杆	Adjusting Bar	1	1	1	1
J-28	44-00000013-00	差动微调标签(不干胶)	Label	1	1	1	1
J-29	24-03000000-08	差动微调开口挡圈	Ring	1	1	1	1
J-30	2316-10-26	差动微调弹簧	Spring	1	1	1	1
J-31	2316-10-27	差动微调导向柱	Guidepost	1	1	1	1
J-32	2316-10-28	差动板手轴套	Plate Hand Sleeve	1	1	1	1
J-33	2316-10-29	送布轴	Shaft	1	1	1	1
J-34	24-07000000-08	送布轴开口挡圈	Ring E7	1	1	1	1
J-35	209-10-03	送布轴孔橡皮塞	Plug	1	1	1	1
J-36	2316-08-07	送布轴垫圈	Washer	2	2	2	2
J-37	2316-10-30	差动滑杆曲柄组件	Crank	(1)	(1)	(1)	(1)
J-37-1	2316-10-30-01	差动滑动座盖	Differential Sliding Seat Cover	(1)	(1)	(1)	(1)
J-37-2	2316-10-30-02	差动滑动座	Differential Sliding Seat	(1)	(1)	(1)	(1)
J-37-3	2316-10-30-03	差动滑杆曲柄	Crank	(1)	(1)	(1)	(1)
J-38	12-65601222-01	差动曲柄夹紧螺钉	Bolt	1	1	1	1
J-39	2316-10-30-04	差动滑动座螺钉	Screw	(2)	(2)	(2)	(2)

J. 差动调节部件 Feed Mechanism

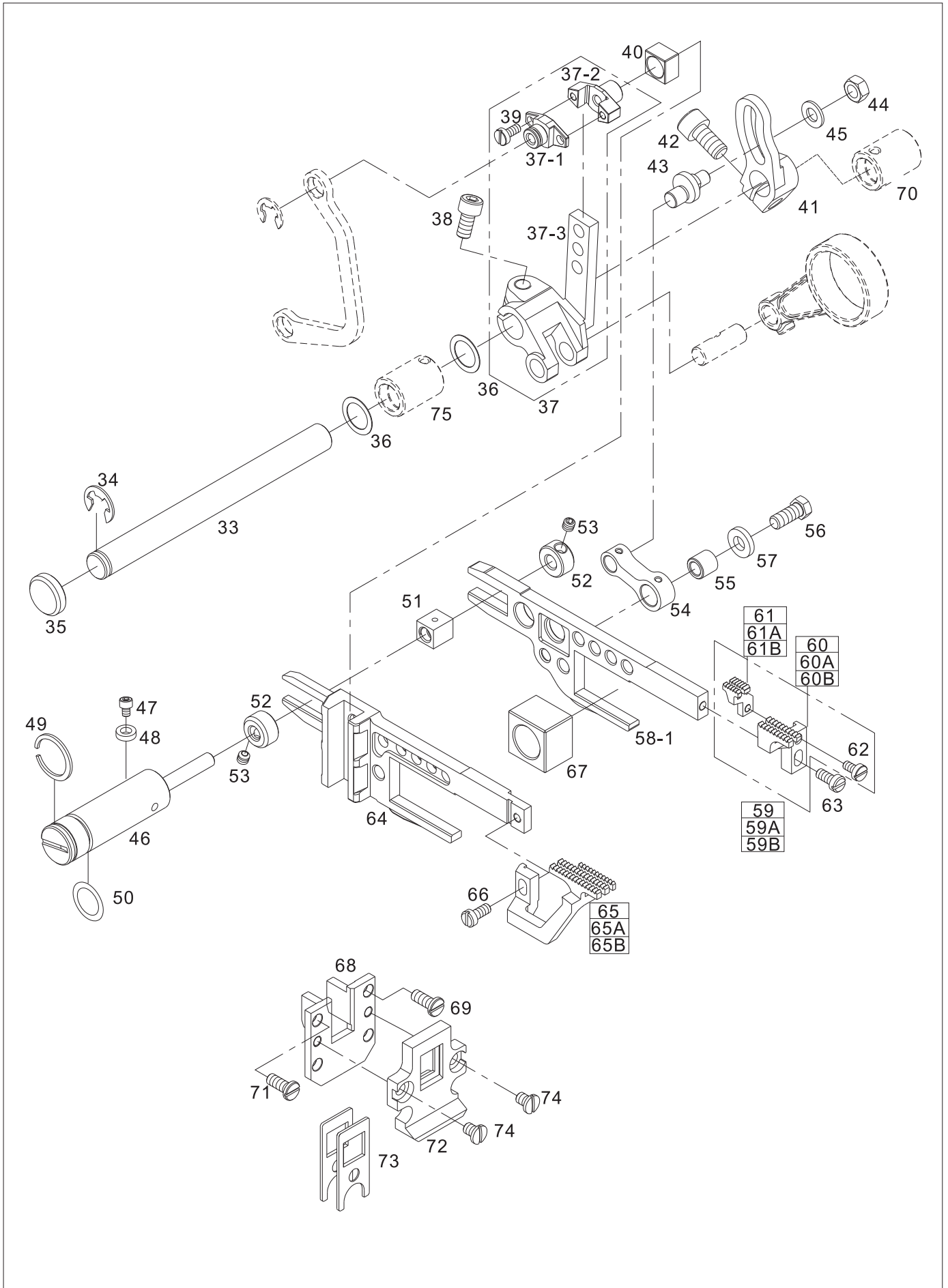

J.差动调节部件 Feed Mechanism

序号 NO.	图号 REF NO.	名称	DESCRIPTION	数量 AMT			
				3线	4线	5线	5H
J-40	2316-10-31	差动牙架滑块	Block	1	1	1	1
J-41	2316-10-32	送布调节曲柄	Crank	1	1	1	1
J-42	12-65601222-01	送布曲柄夹紧螺钉	Bolt M6x12	1	1	1	1
J-43	2316-10-33	送布调节偏心销	Pin	1	1	1	1
J-44	14-60504020-01	送布偏心销螺母	Nut	1	1	1	1
J-45	21-05111110-02	送布偏心销垫圈	Washer	1	1	1	1
J-46	2316-10-34	调牙偏心轴	Pin	1	1	1	1
J-47	12-60400522-01	调牙偏心轴螺钉	Bolt M4x5	1	1	1	1
J-48	2316-10-35	调牙偏心轴螺钉垫圈	Gasket	1	1	1	1
J-49	2316-10-36	调牙偏心轴挡圈	Ring	1	1	1	1
J-50	31-11515000-09	调牙偏心轴O型圈	O Ring	1	1	1	1
J-51	2316-10-37	差动送布滑块	Block	1	1	1	1
J-52	2316-10-38	差动送布滑块紧圈	Collar	2	2	2	2
J-53	12-80400412-01	差动送布滑块紧圈螺钉	Screw M4x4	2	2	2	2
J-54	2316-10-54	送布牙架连杆	Feed Braces Connecting Rod	1	1	1	1
J-55	2316-09-03	送布牙架连杆滚柱	Bushing	1	1	1	1
J-56	12-95501323-01	送布牙架连杆滚柱螺钉	Bolt M5x12	1	1	1	1
J-57	21-05111110-02	送布牙架连杆滚柱垫圈	Washer	1	1	1	1
J-58	2316-10-41-00	牙架组件	Main Feed Bar	1	1	1	1
J-58-1	2316-10-41	送布牙架	Main Feed Bar	(1)	(1)	(1)	(1)
J-59	2316-10-42	送布牙组件(三、四线)	Feed Dog Components	1	1		
J-59A	2316-10-42A	送布牙组件(五线)	Feed Dog Components			1	
J-59B	2316-10-42B	送布牙组件(厚料)	Feed Dog Components				1
J-60	2316-10-42-01	送布牙(三、四线)	Feed Dog	(1)	(1)		
J-60A	2316-10-42-01A	送布牙(五线)	Feed Dog			(1)	
J-60B	2316-10-42-01B	送布牙(厚料)	Feed Dog				(1)
J-61	2316-10-42-02	副送布牙(三、四线)	Pay Feed Dog	(1)	(1)		
J-61A	2316-10-42-02A	副送布牙(五线)	Pay Feed Dog			(1)	
J-61B	2316-10-42-02C	副送布牙((厚料))	Pay Feed Dog				(1)
J-62	12-60300620-01	副送布牙(送线牙)螺钉	Pay Feed Dog Screw M3x6	(1)	(1)	(1)	(1)
J-63	12-60350820-01	送布牙螺钉	Screw M3.5x8	1	1	1	1
J-64	2316-10-43	差动牙架	Defferential Feed Bar	(1)	(1)	(1)	(1)
J-65	2316-10-44	差动牙(三、四线)	Defferential Feed Dog	(1)	(1)		
J-65A	2316-10-44A	差动牙	Defferential Feed Dog			(1)	
J-65B	2316-10-44B	差动牙	Defferential Feed Dog				(1)
J-66	12-40350825-01	差动牙螺钉	Screw M3.5x8	1	1	1	1
J-67	2316-10-45	抬牙滑块	Block	1	1	1	1
J-68	2316-10-46	牙架右导板	Feed Bar Guide(right)	1	1	1	1
J-69	12-60400822-01	牙架右导板螺钉	Feed Bar Guide Screw M4x8	2	2	2	2
J-70	2316-07-24	送布轴右轴套	Shaft	1	1	1	1
J-71	12-60400822-01	牙架左导板螺钉	Feed Bar Guide Screw M4x8	2	2	2	2
J-72	2316-10-48	牙架密封座	Braces Seal Seat	1	1	1	1
J-73	2316-10-49A	牙架油封	Braces Oil Seal	2	2	2	2
J-74	12-60400522-01	牙架密封座螺钉	Bolt M4x5	3	3	3	3
J-75	2316-10-53	送布轴左轴套	Shaft	1	1	1	1

K.上下切刀部件 Knife Drive Mechanism

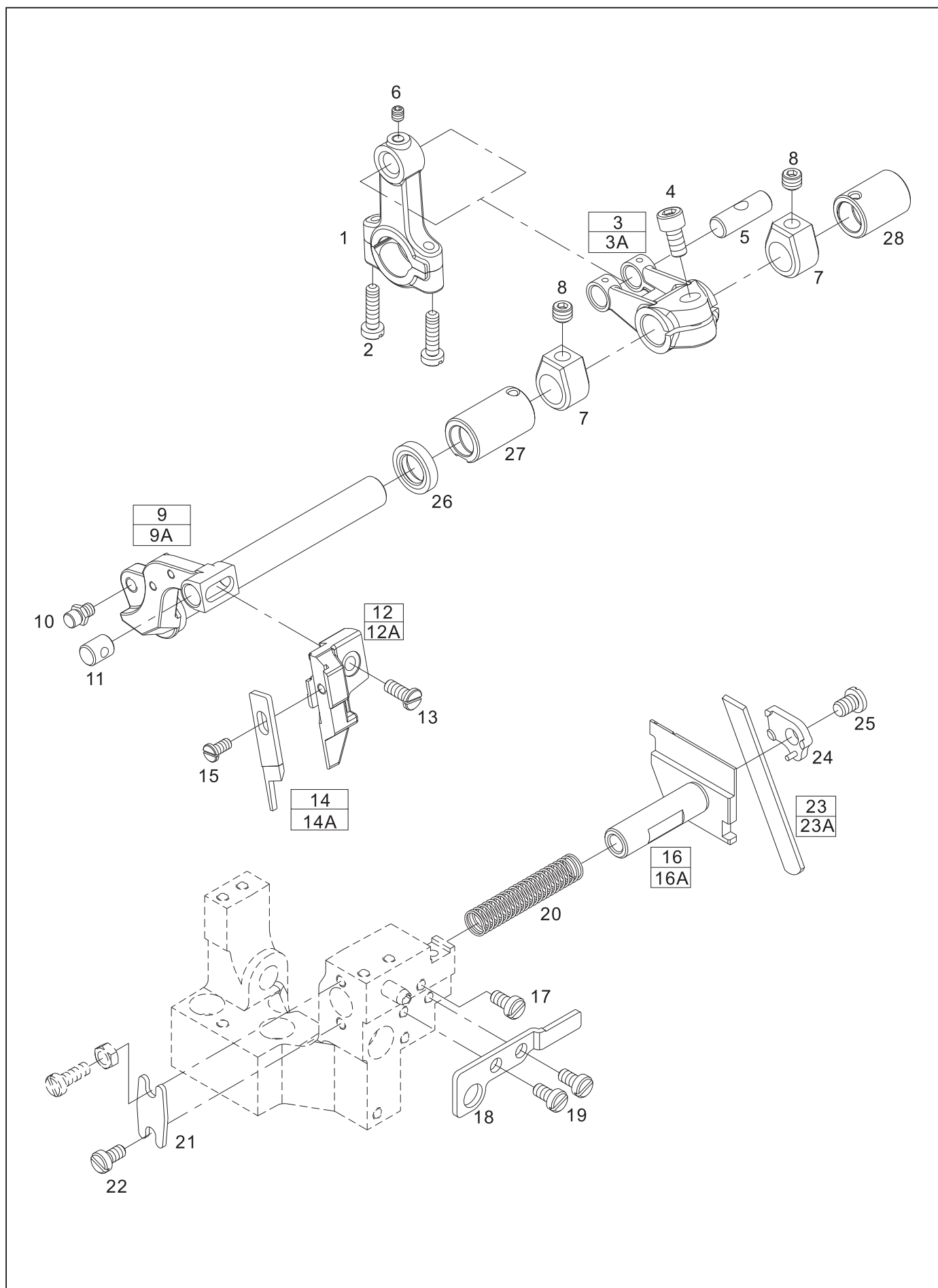

K.上下切刀部件 Knife Drive Mechanism

序号 NO.	图号 REF NO.	名称	DESCRIPTION	数量 AMT			
				3线	4线	5线	5H
K-1	2316-11-01	上切刀连杆	Connection	(1)	(1)	(1)	(1)
K-2	12-60401620-01	上切刀连杆螺钉	Screw M4x16	(2)	(2)	(2)	(2)
K-3	2316-11-02	上切刀曲柄	Crank	(1)	(1)		
K-3A	2316-11-02A	上切刀曲柄	Crank			(1)	(1)
K-4	12-65601222-01	上切刀曲柄夹紧螺钉	Bolt	(1)	(1)	(1)	(1)
K-5	209-05-19	上切刀曲柄销	Pin	(1)	(1)	(1)	(1)
K-6	12-80400612-01	上切刀曲柄销紧固螺钉	Screw M4x6	(1)	(1)	(1)	(1)
K-7	2316-11-03	上切刀轴紧圈	Collar	(2)	(2)	(2)	(2)
K-8	12-80600512-01	上切刀轴紧圈螺钉	Screw M6x5	2	2	2	2
K-9	2316-11-04	上切刀轴	Upper Knife Lever	1	1	1	
K-9A	2316-11-04A	厚料上切刀轴	Upper Knife Lever				1
K-11	2316-11-06	上切刀座连接销	Pin	1	1	1	1
K-12	2316-11-07	上切刀座	Upper Knife Clamp	1	1		
K-12A	2316-11-07A	上切刀座	Upper Knife Clamp			1	1
K-13	12-40401225-01	上切刀座螺钉	Screw M4x12	1	1	1	1
K-14	2316-11-08	上切刀	Flate Knife	1	1	1	
K-14A	2316-11-08A	上切刀	Flate Knife				1
K-15	12-60350820-01A	上切刀螺钉	Screw M3x8	1	1	1	1
K-16	2316-11-09	下切刀座	Upper Knife Clamp	1	1		
K-16A	2316-11-09A	下切刀座	Upper Knife Clamp			1	
K-16B	2316-11-09B	下切刀座	Upper Knife Clamp				1
K-17	12-40401025-01	下切刀座紧固螺钉	Screw M4x10	1	1	1	1
K-18	2316-11-10	下切刀座导向板	Lower Knife Holder Guide	1	1	1	1
K-19	12-40400825-01	下切刀座导向板螺钉	Screw M4x8	2	2	2	2
K-20	2316-11-11	下切刀座弹簧	Spring	1	1	1	1
K-21	2316-11-12	下切刀座弹簧限位板	Plate	1	1	1	1
K-22	12-40400825-01	下切刀座弹簧限位板螺钉	Screw M4x7.4	1	1	1	1
K-23	2316-11-13	下切刀	Lower Knife (thick)	2	2	2	
K-23A	2316-11-13A	下切刀	Lower Knife (heavy)				2
K-24	2316-11-14	下切刀压板	Lower Knife Clamp	1	1	1	1
K-25	12-90500820-01	下切刀压板螺钉	Bolt M5x8	1	1	1	1
K-26	32-10030150-09	上切刀轴左轴套油封	Oil Seal	1	1	1	1
K-27	2316-11-15	上切刀轴左轴套	Front Bush For Knife Driving Shaft	1	1	1	1
K-28	2316-11-21	上切刀轴右轴套	Rear Bush For Knife Driving Shaft	1	1	1	1
K-29	2316-11-16	厚料上刀座	On Cutter Holder				1
K-30	2316-11-17	上切刀锁紧垫圈	Washer				1
K-31	2316-11-18	厚料上切刀(三角)	On Cutter				1
K-32	12-60300420-01	厚料上切刀螺钉	Screw M3x3.7				1
K-33	2316-11-19	厚料上刀座垫板	On Cutter Holder Plate				1
K-34	2316-11-20	厚料上刀座压板	On Cutter Holder Clamp				1
K-35	12-60401620-01	厚料上刀座压板螺钉	Screw M4x16				1

L.抬压脚部件 Press Foot Mechanism

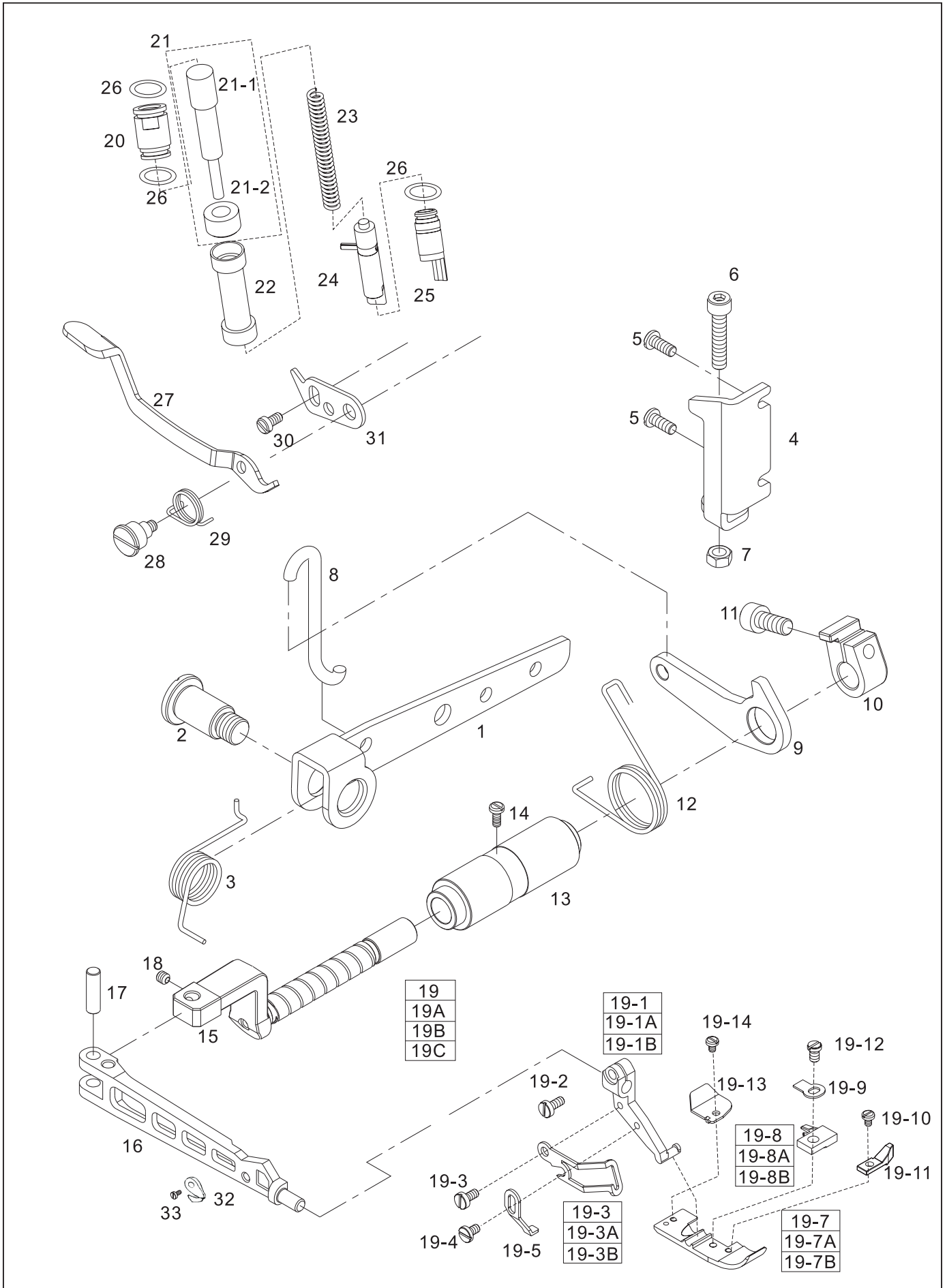

L.抬压脚部件 Press Foot Mechanism

序号 NO.	图号 REF NO.	名称	DESCRIPTION	数量 AMT			
				3线	4线	5线	5H
L-1	2316-12-01	抬压脚杠杆	Lever	1	1	1	1
L-2	209-12-10	抬压脚杠杆轴位螺钉	Screw	1	1	1	1
L-3	2316-12-02	抬压脚杠杆复位扭簧	Spring	1	1	1	1
L-4	2316-12-03	抬压脚杠杆限位架	Stopper	1	1	1	1
L-5	12-40401225-01	抬压脚杠杆限位架螺钉	Screw M4×L12	2	2	2	2
L-6	12-60502522-01	抬压高度限位调节螺钉	Screw M5X25	1	1	1	1
L-7	14-60504020-01	抬压高度限位调节螺母	Nut	1	1	1	1
L-8	209-12-11	抬压脚杠杆吊勾	Link	1	1	1	1
L-9	2310-08-09	抬压脚轴杠杆	Lever	1	1	1	1
L-10	209-12-06	抬压脚轴紧圈	Crank	1	1	1	1
L-11	12-65601422-01	抬压脚轴紧圈夹紧螺钉	Bolt M6X14	1	1	1	1
L-12	209-12-04	抬压脚轴杠杆复位扭簧	Spring	1	1	1	1
L-13	2316-12-04	抬压脚轴套	Bush for Presser Foot Shaft	1	1	1	1
L-14	12-60402522-01	抬压脚轴套紧固螺钉	Screw m4x25	1	1	1	1
L-15	2316-12-05	抬压脚轴	SHAFT	(1)	(1)	(1)	(1)
L-16	2316-12-06	压脚臂	Presser Arm	(1)	(1)	(1)	(1)
L-17	209-12-17	压脚臂铰链轴	Pin	1	1	1	1
L-18	12-80400412-01	压脚臂铰链轴紧固螺钉	Screw m4x4	1	1	1	1
L-19	2316-12-07	压脚组件(三线)	Presser Foot Assy.	1			
L-19A	2316-12-07B	压脚组件(四线)	Presser Foot Assy.		1		
L-19B	2316-12-07C	压脚组件(五线)	Presser Foot Assy.			1	
L-19C	2316-12-07D	压脚组件(厚料)	Presser Foot Assy.				1
L-19-1	2316-12-07-01	压脚柄架	HOLDER	(1)	(1)		
L-19-1A	2316-12-07-01A	压脚柄架	HOLDER			(1)	
L-19-1B	2316-12-07-01B	压脚柄架	HOLDER				(1)
L-19-2	12-60350820-01	压脚柄架夹紧螺钉	SCREW M3.5X8	(1)	(1)	(1)	(1)
L-19-3	2316-12-07-03	护指簧	Spring	(1)	(1)		
L-19-3A	2316-12-07-03A	护指簧	Spring			(1)	
L-19-3B	2316-12-07-03B	护指簧	Spring				(1)
L-19-4	12-60300420-01A	护指簧螺钉	Screw M3x3.5	(1)	(1)	(1)	(1)
L-19-5	2316-12-07-05	压脚后限位板	Stopper	(1)	(1)	(1)	(1)
L-19-6	12-60300420-01	压脚后限位板螺钉	Screw M3x4	(1)	(1)	(1)	(1)
L-19-7	2316-12-07-07	压脚底板	PRESSER FOOT	(1)	(1)		
L-19-7A	2316-12-07-07	压脚底板	PRESSER FOOT			(1)	
L-19-7B	2316-12-07-07	压脚底板	PRESSER FOOT				(1)
L-19-8	2316-12-07-08	编结小舌头	PRESSER FOOT finger	(1)	(1)		
L-19-8A	2316-12-07-08A	编结小舌头	PRESSER FOOT finger			(1)	
L-19-8B	2316-12-07-08B	编结小舌头	PRESSER FOOT finger				(1)
L-19-9	2316-12-07-09	压脚小舌头压板	Spring	(1)	(1)	(1)	(1)
L-19-10	2316-12-07-10	压脚缝料前压板螺钉	Screw	(1)	(1)	(1)	(1)
L-19-11	2316-12-07-11	压脚缝料前压板	Fabric guide	(1)	(1)	(1)	(1)
L-19-12	2316-12-07-12	压脚缝料后压板螺钉	Screw	(1)	(1)	(1)	(1)
L-19-13	2316-12-07-13	压脚缝料后压板	Uncurler	(1)	(1)	(1)	(1)
L-19-14	2316-12-07-14	压脚小舌头压板螺钉	Screw	(1)	(1)	(1)	(1)
L-20	2319-01-18	压杆上套	Cover	1	1	1	1
L-21	2319-01-19	调压组件	Voltage regulation	1	1	1	1
L-21-1	2319-01-19-01	调压螺钉	Screw	(1)	(1)	(1)	(1)
L-21-2	2319-01-19-02	调压螺母	NUT	(1)	(1)	(1)	(1)
L-22	2319-01-20	压杆防油罩	Cover	1	1	1	1
L-23	2319-01-21	调压弹簧	Spring	1	1	1	1
L-24	2319-01-22	压紧杆组件	Compression bar	1	1	1	1
L-25	2319-01-23	压杆下套	Cover	1	1	1	1
L-26	31-11515000-09	O型圈	O Ring	3	3	3	3
L-27	2319-01-08	抬压脚扳手	Wrench	1	1	1	1
L-28	209-12-27	抬压板手轴位螺钉	Screw	1	1	1	1
L-29	2319-01-17	抬压板手复位扭簧	Spring	1	1	1	1
L-30	12-40400825-01	螺钉	Screw	2	2	2	2
L-31	2316-12-12	抬压板手限位板	STOPPER	1	1	1	1
L-32	2316-12-13	割线刀	Thread Cutter	1	1	1	1
L-33	12-70300825-01	割线刀螺钉	Screw	1	1	1	1

M. 润滑部件 Lubrication Mechanism

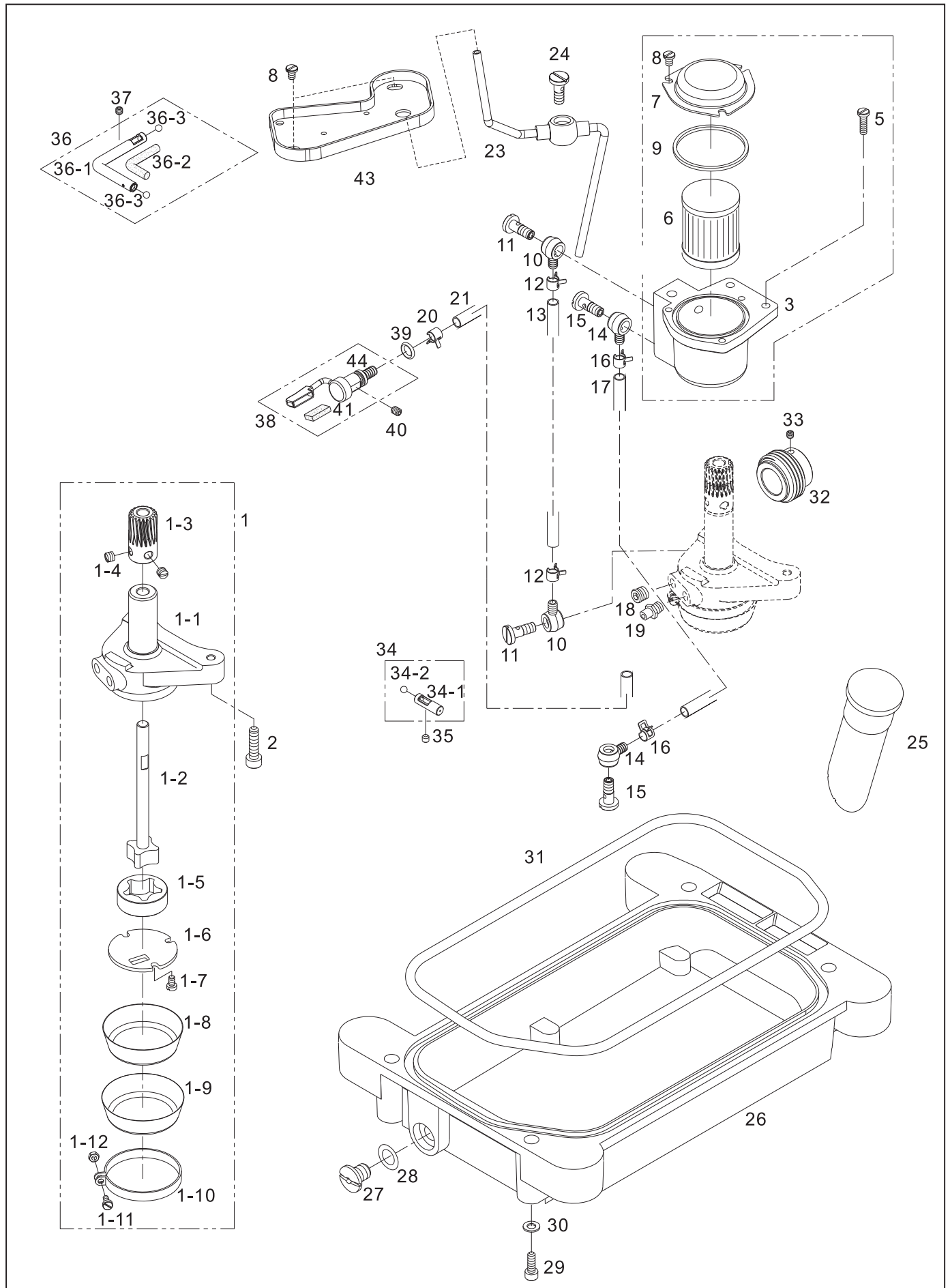

M.润滑部件 Lubrication Mechanism

序号 NO.	图号 REF NO.	名称	DESCRIPTION	数量 AMT			
				3线	4线	5线	5H
M-1	2316-13-01	油泵大组件	Pump Ass'y	1	1	1	1
M-1-1	2316-13-01-01	油泵体	Pump Housing	(1)	(1)	(1)	(1)
M-1-2	2316-13-01-02	油泵轴组件	Rotor (Inside) Shaft	(1)	(1)	(1)	(1)
M-1-3	2316-13-01-03	油泵蜗轮	Worm Wheel	(1)	(1)	(1)	(1)
M-1-4	2316-13-01-04	油泵蜗轮螺钉	Screw	(2)	(2)	(2)	(2)
M-1-5	2316-13-01-05	油泵五星齿轮套	Rotor (Outside)	(1)	(1)	(1)	(1)
M-1-6	2316-13-01-06	油泵五星齿轮套盖板	Oil Pump Cover	(1)	(1)	(1)	(1)
M-1-7	12-60350620-01	齿轮套盖板螺钉	Screw	(3)	(3)	(3)	(3)
M-1-8	2316-13-01-08	油泵体内罩	Filter	(1)	(1)	(1)	(1)
M-1-9	2316-13-01-09	油泵体外罩	Filter	(1)	(1)	(1)	(1)
M-1-10	2316-13-01-10	油泵体外罩夹紧圈	Clamp	(1)	(1)	(1)	(1)
M-1-11	12-40300625-01	油泵体外罩夹紧圈螺钉	Screw	(1)	(1)	(1)	(1)
M-1-12	2316-13-01-12	油泵体外罩夹紧圈螺母	Nut	(1)	(1)	(1)	(1)
M-2	12-60401622-01	油泵体螺钉	Screw	2	2	2	2
M-3	2316-13-02	滤油器壳	Tank	1	1	1	1
M-5	12-60401622-01	蜗轮蜗杆供油罩板螺钉	Screw	2	2	2	2
M-6	279-08-23	滤油器	Filter Element	1	1	1	1
M-7	2316-13-05	滤油器盖	Cover	1	1	1	1
M-8	12-40400825-01	螺钉	Screw	5	5	5	5
M-9	2316-13-06	滤油器密封圈	O Ring	1	1	1	1
M-10	2316-13-07	滤油器壳进油接头	Joint	2	2	2	2
M-11	510-10-18	滤油器壳进油接头分油螺钉	Joint Screw	2	2	2	2
M-12	2316-02-38	滤油器壳进油接头出油管夹	Clamp	(2)	(2)	(2)	(2)
M-13	2316-02-39-02	油管	Tube	2	2	2	2
M-14	2316-13-07	滤油器壳出油接头	Joint	2	2	2	2
M-15	510-10-18	滤油器壳出油接头分油螺钉	Joint Screw	2	2	2	2
M-16	2316-02-38	出油接头油管夹	Clamp	2	2	2	2
M-17	2316-13-13-02	出油接头油管	TUBE	1	1	1	1
M-18	12-80600612-01	油泵堵油螺钉	Joint	1	1	1	1
M-19	2316-13-25	油泵体出油接头螺钉	Joint Screw	1	1	1	1
M-20	2316-02-38	针杆回油管夹	Clamp	2	2	2	2
M-21	2316-02-39-02	针杆回油管	Tube	1	1	1	1
M-23	2319-01-13	供油管组件	Tube	1	1	1	1
M-24	12-40401625-01	油泵喷油管固定螺钉	Screw	1	1	1	1
M-25	2319-01-35	油量指示窗	Oil Lever Gauge	1	1	1	1
M-26	2316-13-10	油盘	Oil Reservoir Assy	1	1	1	1
M-27	2316-13-11	油盘放油螺钉	Screw	1	4	4	4
M-28	2316-13-12	油盘放油密封垫	Washer	1	4	4	4
M-29	12-60501222-01	油盘连接螺钉	Screw	4	1	1	1
M-30	21-05518152-02	油盘连接螺钉垫圈	Washer	4	1	1	1
M-31	2316-13-14	油盘密封圈	Rubber Ling	1	1	1	1
M-32	2316-13-15	主轴油泵螺杆	Worm	1	1	1	1
M-33	12-80500512-01	主轴油泵螺杆螺钉	Screw	1	1	1	1
M-34	2316-13-16	上弯针摇杆供油管组件	Rubber Ling	1	1	1	1
M-34-1	2316-12-17	上弯针摇杆供油管	Pipe	(1)	(1)	(1)	(1)
M-34-2	2316-12-18	供油管堵塞	Ball	(2)	(2)	(2)	(2)
M-35	12-80400412-01	供油管螺钉	Screw	1	1	1	1
M-36	2316-13-19	针杆供油管组件	Pipe Assy	1	1	1	1
M-36-1	2316-12-19-01	针杆供油管	Pipe Assy	(1)	(1)	(1)	(1)
M-36-2	2316-12-19-02	针杆供油管油线	Oil Wick	(1)	(1)	(1)	(1)
M-36-3	2316-12-18	针杆供油管堵塞	Oil Wick	(2)	(2)	(2)	(2)
M-37	12-80400412-01	针杆供油管螺钉	Screw	(1)	(1)	(1)	(1)
M-38	2316-13-20	针杆回油嘴	Joint	1	1	1	1
M-39	31-06819000-09	针杆回油嘴O型圈	O Ring	1	1	1	1
M-40	12-80400412-01	供油管组件紧固螺钉	Screw	1	1	1	1
M-41	2316-13-21	针杆回油嘴油毡	Felt	1	1	1	1
M-42	510-10-14	回油嘴螺钉	Screw	1	1	1	1
M-43	2319-01-15	滴油板	Drip plate	1	1	1	1

N.线架与附件 Accessories Mechanism

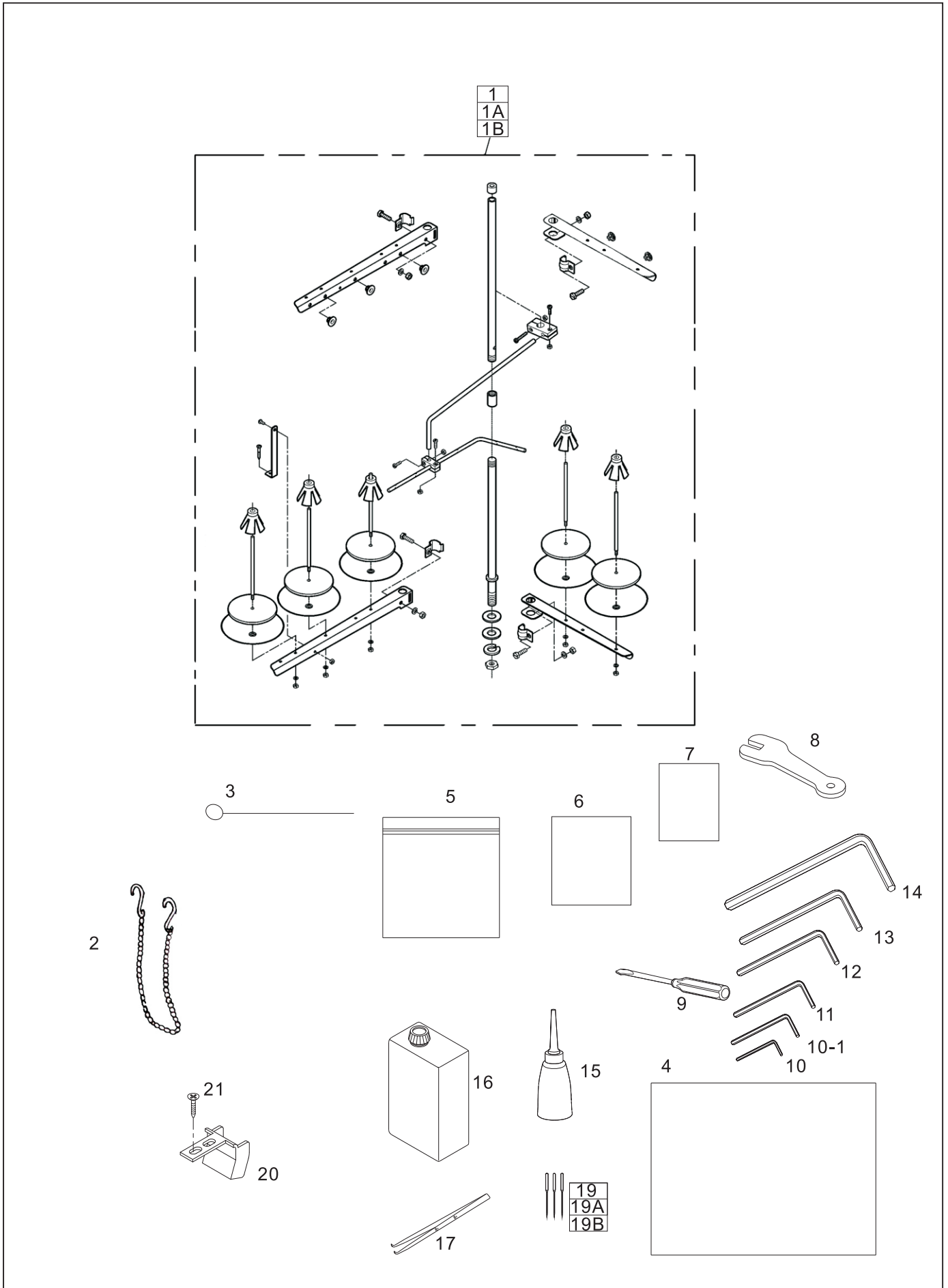

N.线架与附件 Accessories Mechanism

序号 NO.	图号 REF NO.	名称	DESCRIPTION	数量 AMT			
				3线	4线	5线	5H
N-1	279-12-05	五线架组件	Thread Stand(Ass'y)			1	1
N-1A	279-12-04	四线架组件	Thread Stand(Ass'y)		1		
N-1B	279-12-03	三线架组件	Thread Stand(Ass'y)	1			
N-2	279-11-11-00	抬压脚链条及钩	Article Carried The Anklets And Hook	1	1	1	1
N-3	279-11-21	线勾	Line Hook			1	1
N-4	101-12-20	机头塑料袋 (透明)	Head Cover	1	1	1	1
N-5	279-11-20	拉链袋	Accessory Bag	1	1	1	1
N-6	197-104-054	封口袋	Pack12X18	1	1	1	1
N-7	197-104-51	小塑料袋	Pack	1	1	1	1
N-8	2304-11-02	双头扳手	Spanner (8mm)	1	1	1	1
N-9	101-12-15	一字起子 (螺丝刀)	Screw Driver(L)	1	1	1	1
N-10	279-11-29	内六角扳手1.5	L-Type Hexagonal Wrench(1.5mm)	1	1	1	1
N-10-1	279-11-28	内六角扳手2	L-Type Hexagonal Wrench(2mm)	1	1	1	1
N-11	301-20-15	内六角扳手2.5	L-Type Hexagonal Wrench(2.5mm)	1	1	1	1
N-12	301-20-26	内六角扳手3	L-Type Hexagonal Wrench(3mm)	1	1	1	1
N-13	301-20-28	内六角扳手4	L-Type Hexagonal Wrench(4mm)	1	1	1	1
N-14	301-20-30	内六角扳手6	L-Type Hexagonal Wrench(6mm)	1	1	1	1
N-15	279-11-18	油壶	Oiler	1	1	1	1
N-16	101-12-21-07/02	油箱 (专用T18号白油)	Bottle of Oil	1	1	1	1
N-17	279-11-24	不锈钢穿线镊子	Thread Tweezers	1	1	1	1
N-19	279-02-30	机针DC*27 #11	Needle	3	1		
N-19A	279-02-30A	机针DC*27 #14	Needle		3	3	
N-19B	206-02-08	机针DC*27 #18	Needle				3
N-20	301-20-05	护板	Guard plate	1	1	1	1
N-21	563-21-82	木螺钉	Screw	4	4	4	4

N.线架与附件 Accessories Mechanism

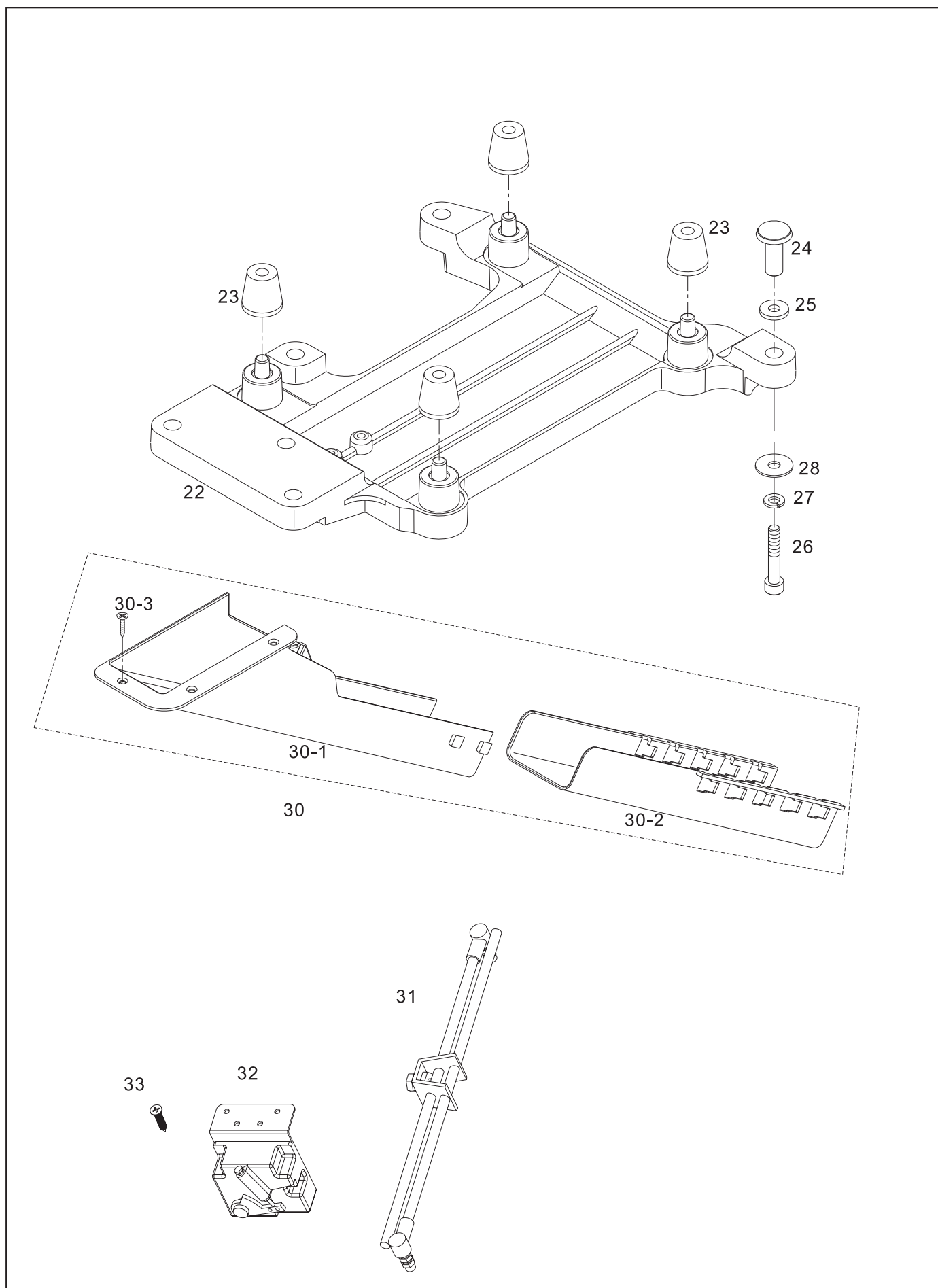

N.线架与附件 Accessories Mechanism

序号 NO.	图号 REF NO.	名称	DESCRIPTION	数量 AMT			
				3线	4线	5线	5H
N-22	2316-14-05	托盘	Tray	1	1	1	1
N-23	2316-14-06	机头托盘头减振垫	Rest Board	4	4	4	4
N-24	2316-14-11	机头托盘固定螺母	Cushion Rubber	4	4	4	4
N-25	2316-14-07	机头托盘固定螺母垫圈	Nut	4	4	4	4
N-26	2316-14-12	机头托盘连接螺钉	Spacer	4	4	4	4
N-27	22-08000000-08	机头托盘连接弹簧垫圈	Bolt(M8xL45)	4	4	4	4
N-28	279-11-05-02	机头托盘连接螺钉垫圈	Spring Washer	4	4	4	4
N-30	2316-14-08	废料漏斗组件	Washer	1	1	1	1
N-30-1	2316-13-08-01	排料槽上节	Waste Chute(Top)	(1)	(1)	(1)	(1)
N-30-2	2316-13-08-02	排料槽下节	Waste Chute(Botton)	(1)	(1)	(1)	(1)
N-30-3	2316-13-08-03	排料槽上节木螺钉	Waste Chute(Lower)	(3)	(3)	(3)	(3)
N-31	2319-01-25-05	拉杆	Washer(4)	1	1	1	1
N-32	2319-01-25-04	踏板	Pedal	1	1	1	1
N-33	197-13-9010	木螺钉	Pull Rod	4	4	4	4

O.E4专用部件 E4. Special Mechanism

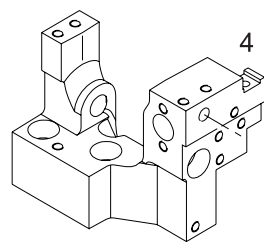
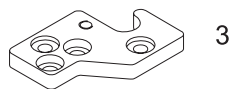
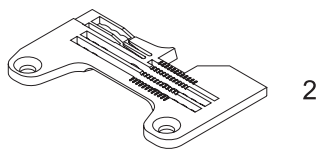
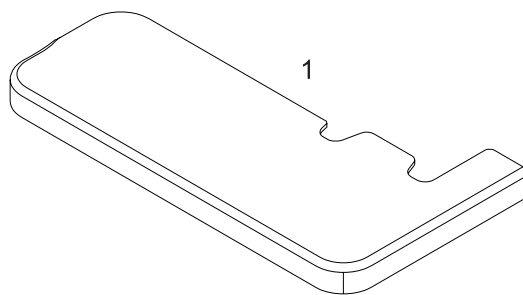

O.E4专用部件 E4. Special Mechanism

序号 NO.	图号 REF NO.	名称	DESCRIPTION	数量 AMT(E4)			
				3线	4线	5线	5H
0-1	2319-01-14	缝台组件	Cloth Plate Ass'y	1	1	1	1
0-2	2316-16-04B	三线针板	Needle plate	1			
	2316-16-04	四线针板	Needle plate		1		
	2316-16-04A	五线针板	Needle plate			1	
	2316-16-04C	五线厚料针板	Needle plate				1
0-3	2316-16-05	前针板垫	Bracket (Font)	1	1	1	1
0-4	2316-16-02	针板垫支架	Bracket	1	1	1	1

P.全自动部件 Automatic Thread Trimming Mechanism

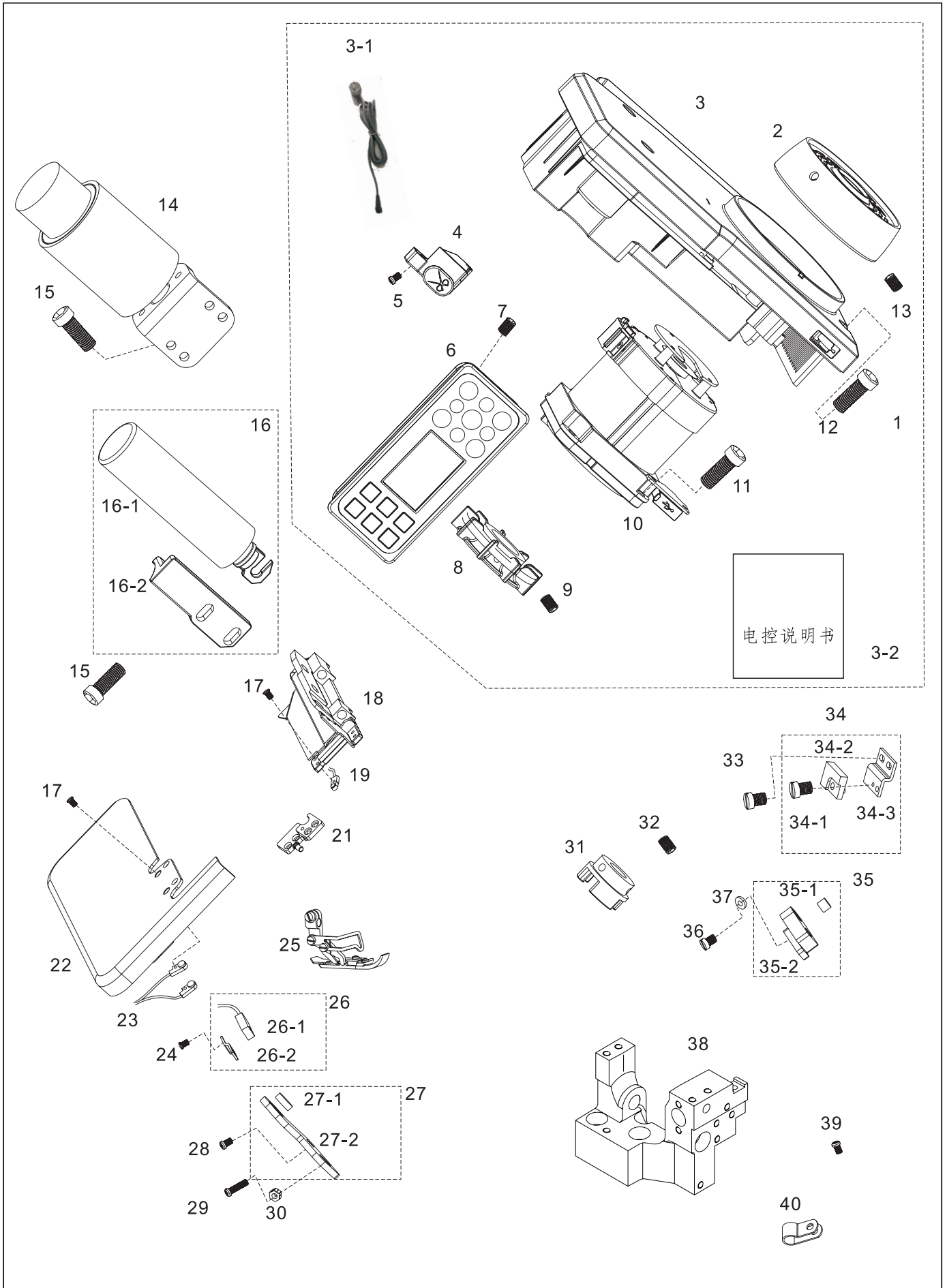

P.全自动部件 Automatic Thread Trimming Mechanism

序号 NO.	图号 REF NO.	名称	DESCRIPTION	数量 AMT(E4)			
				3线	4线	5线	5H
P-1	2319-01-25	电机电控组件	Electric Control Module Of Motor	1	1	1	1
P-2	2319-01-25-11	手轮	Handle Wheel	(1)	(1)	(1)	(1)
P-3	2319-01-25-12	电控	Motor Asm	(1)	(1)	(1)	(1)
P-3-1	2319-01-25-12-02	插头		(1)	(1)	(1)	(1)
P-3-2	2319-01-25-15	电控说明书		(1)	(1)	(1)	(1)
P-4	2319-01-25-06	上光眼	Sensor	(1)	(1)	(1)	(1)
P-5	12-40401225-01	上光眼固定螺钉	Screw	(2)	(2)	(2)	(2)
P-6	2319-01-25-01	显示屏组件	Display	(1)	(1)	(1)	(1)
P-7	12-80400412-01	显示屏限位螺钉	Screw	(2)	(2)	(2)	(2)
P-8	2319-01-25-03	风叶	Fan	(1)	(1)	(1)	(1)
P-9	12-80600612-01	风叶固定螺钉	Screw	(3)	(3)	(3)	(3)
P-10	2319-01-25-02	伺服电机	Motor	(1)	(1)	(1)	(1)
P-11	12-60502722-01	电机固定螺钉	Screw	(4)	(4)	(4)	(4)
P-12	12-60505022-01	电控固定螺钉	Screw	(4)	(4)	(4)	(4)
P-13	11-80150810-01	手轮固定螺钉	Screw	(2)	(2)	(2)	(2)
P-14	2319-01-29	抬压电磁铁组件	Electromagnet	1	1	1	1
P-15	12-60601422-01	电磁铁安装螺钉	Screw	6	6	6	6
P-16	2319-01-28	剪线电磁铁组件	Electromagnet	1	1	1	1
P-16-1	2319-01-28-1	剪线电磁铁	Electromagnet	1	1	1	1
P-16-2	2319-01-28-2	剪线电磁铁安装板	Plate	1	1	1	1
P-17	11-10380520-01	下光眼固定螺钉	Screw	3	3	3	3
P-18	2319-01-27	剪线刀组件	Knife	1	1	1	1
P-19	2319-01-25-08	第三下光眼	Light Eye	(1)	(1)	(1)	(1)
P-21	2316-16-02	针板前支架	Plate	1	1	1	1
P-22	2319-01-14	自动剪线缝台组件	Sewing	1	1	1	1
P-23	2319-01-25-07	下光眼	Light Eye	(1)	(1)	(1)	(1)
P-24	12-60400520-01	缝台安全开关固定螺钉	Screw	1	1	1	1
P-25	2316-12-07	三线压脚组件	Presser Foot	1			
	2316-12-07B	四线压脚组件	Presser Foot		1		
	2316-12-07C	五线压脚组件	Presser Foot			1	
	2316-12-07D	厚料压脚组件	Presser Foot				1
P-26	2319-01-25-09	缝台安全开关组件	Safety Switch	1	1	1	1
P-26-1	2319-01-25-09-1	缝台安全开关	Safety Switch	(1)	(1)	(1)	(1)
P-26-2	2319-01-25-09-2	缝台安全开关安装板	Plate	(1)	(1)	(1)	(1)
P-27	2319-01-25-13	缝台磁铁组件	Magnet Assembly	1	1	1	1
P-27-1	2319-01-25-13-1	缝台磁铁	Magnet	(1)	(1)	(1)	(1)
P-27-2	2319-01-25-13-1	缝台磁铁支架	Bracket	(1)	(1)	(1)	(1)
P-28	12-40400625-01	缝台磁铁固定组件螺钉	Screw	1	1	1	1
P-29	12-40401225-01	缝台磁铁固定组件螺钉	Screw	1	1	1	1
P-30	14-60403020-01	缝台磁铁固定组件螺母	Nut	1	1	1	1
P-31	1281-05-08	联轴器B	Coupling	1	1	1	1
P-32	12-85600812-01	联轴器B螺钉	Screw	3	3	3	3
P-33	12-60300520-01A	压脚臂安全开关螺钉	Screw	1	1	1	1
P-34	2319-01-25-10	压脚臂安全开关组件	Safety Switch Assembly	1	1	1	1
P-34-1	2319-01-25-10-1	安全开关固定螺钉	Screw	(1)	(1)	(1)	(1)
P-34-2	2319-01-25-10-2	安全开关	Safety Switch	(1)	(1)	(1)	(1)
P-34-3	2319-01-25-10-3	安全开关固定支架	Bracket	(1)	(1)	(1)	(1)
P-35	2319-01-25-14	压脚臂磁铁组件	Magnet Assembly	1	1	1	1
P-35-1	2319-01-25-14-1	压脚臂磁铁	Magnet	(1)	(1)	(1)	(1)
P-35-2	2319-01-25-14-2	压脚臂固定支架	Bracket	(1)	(1)	(1)	(1)
P-36	12-70400820-01	压脚臂磁铁固定螺钉	Screw	1	1	1	1
P-37	21-04010090-01	螺钉垫片	Shim	1	1	1	1
P-38	2316-16-02	针板前支架	Bracket	1	1	1	1
P-39	12-40400825-01	电线夹螺钉	Screw	5	5	5	5
P-40	2319-01-44	电线夹	Clamp	7	7	7	7

Q .直驱部件 Direct drive Mechanism

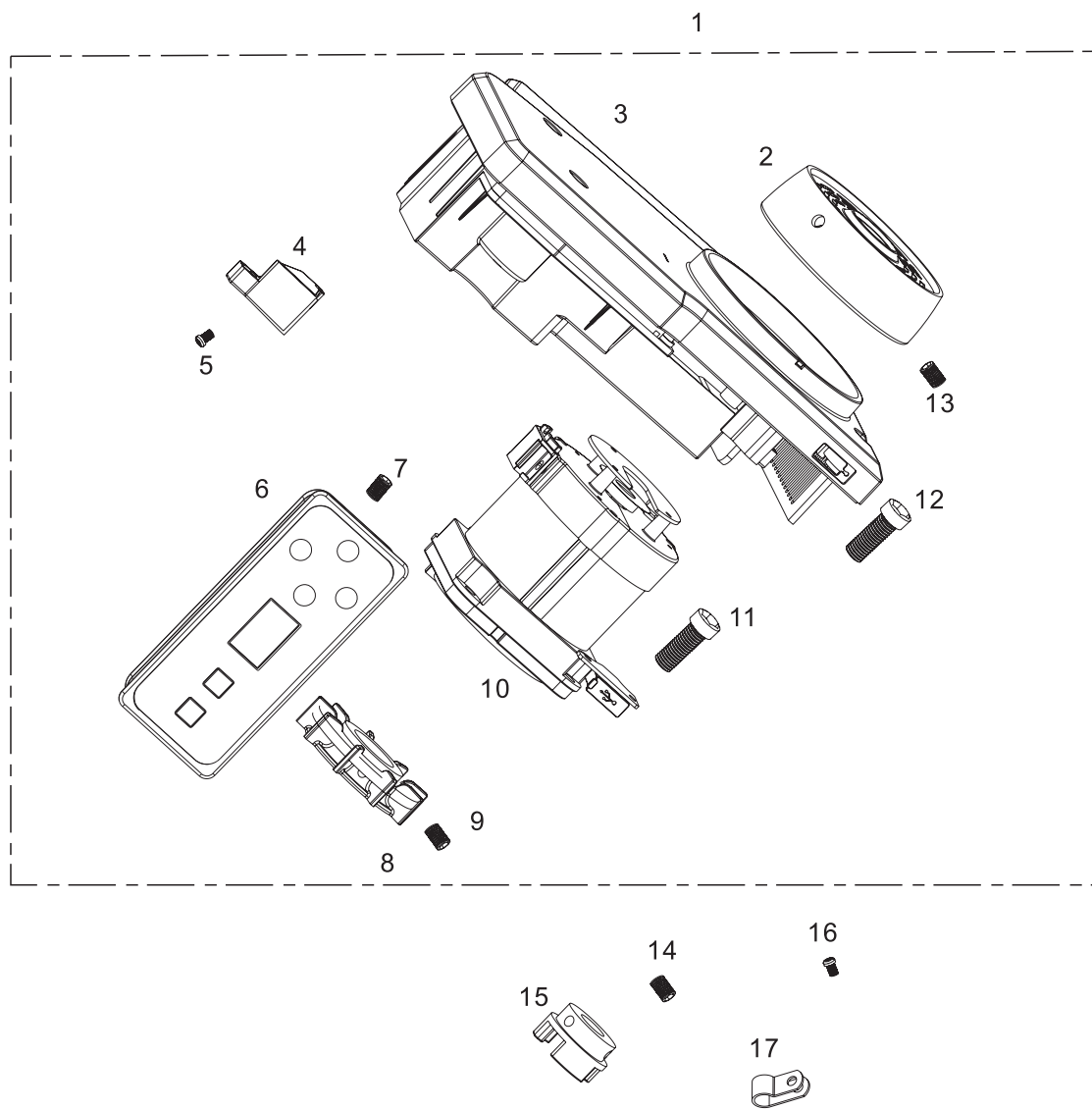

Q.直驱部件 Direct Drive Mechanism

序号 NO.	图号 REF NO.	名称	DESCRIPTION	数量 AMT(E4)			
				3线	4线	5线	5H
Q-1	2319-01-26	电机电控组件	Electric Control Module Of Motor	1	1	1	1
Q-2	2319-01-25-11	手轮	Handle Wheel	(1)	(1)	(1)	(1)
Q-3	2319-01-26-01	电控	Motor Asm	(1)	(1)	(1)	(1)
Q-4	3219-01-26-02	照明灯	Lamp	(1)	(1)	(1)	(1)
Q-5	12-40401225-01	照明灯固定螺钉	Screw	(2)	(2)	(2)	(2)
Q-6	2319-01-26-03	显示屏组件	Display	(1)	(1)	(1)	(1)
Q-7	12-80400412-01	显示屏限位螺钉	Screw	(2)	(2)	(2)	(2)
Q-8	2319-01-25-03	风叶	Fan	(1)	(1)	(1)	(1)
Q-9	12-80600612-01	风叶固定螺钉	Screw	(3)	(3)	(3)	(3)
Q-10	2319-01-25-02	伺服电机	Motor	(1)	(1)	(1)	(1)
Q-11	12-60502722-01	电机固定螺钉	Screw	(4)	(4)	(4)	(4)
Q-12	12-60505022-01	电控固定螺钉	Screw	(4)	(4)	(4)	(4)
Q-13	11-80150810-01	手轮固定螺钉	Screw	(2)	(2)	(2)	(2)
Q-14	12-85600812-01	联轴器固定螺钉	Screw	3	3	3	3
Q-15	1281-05-08	联轴器B	Plate	1	1	1	1
Q-16	12-40400825-01	电线夹螺钉	Screw	2	2	2	2
Q-17	2319-01-44	电线夹	Wire CLIP	2	2	2	2

产品标准编号：QB/T 4388-2012